

Complete Plans for Building a Dobsonian Telescope

from: [The San Francisco Sidewalk Astronomers](#) and Ray Cash

[Introduction and Photo of Completed 'Scope](#)

[Not-too-tech advice; Materials List; Tool List; Sources List](#)

NEW!

[Overview Drawing of 4.5" 'Scope with Plywood Cut Pattern](#)

[Overview Drawing of Six-inch 'Scope with Plywood Cut Pattern](#)

[Overview Drawing of Eight-inch 'Scope with Plywood Cut Pattern](#)

[Overview Drawing of Ten-Inch 'Scope with Plywood Cut Pattern](#)

[Section "A": Preparing the Tube, Making "Spider"; Eyepiece Tube](#)

[Section "B"; "Tailgate" \(Mirror Cell\) Construction](#)

[Section "C"; Making the Mount; Finishing Tips; Care Instructions](#)

[Building a Dobsonian Sun Telescope](#)

[Frequently Asked Questions](#)



[A Testimonial](#)



Dan Gargel with 6" scope made from these plans.

To my other WebPages:

[Astro-images](#)

[My Vanity Page](#)

[My Deep-Sky Page](#)

[How to Build a 13" Travel Scope](#)

[The San Francisco Sidewalk Astronomers](#)

raycash@sbcglobal.net

*(send me pictures of your
finished scope!)*

[My Fastar CCD Page](#)

[Some Furniture I've Made](#)



Plans for Building a Dobsonian Telescope

brought to you by: [The San Francisco Sidewalk Astronomers](#)



Yes, it "looks like a cannon," but the above is really a ten-inch (measured by the diameter of the objective) Newtonian telescope that almost *anybody* can build. Here you will find plans to build this telescope, or a smaller one--either a 4.5", a six-inch, or an eight-inch--of identical design. These plans are only slightly modified from the plans *The Sidewalk Astronomers* have been sending to interested parties for a mere \$2.00 via snail-mail. I have kept as close to this design as possible: One, because this is--hands down--the cheapest and easiest way to make a quality telescope; and two, because I walk in the shadow of John Dobson, who invented many of these designs which have revolutionized amateur and professional astronomy alike... Besides, *Los Angeles Sidewalk Astronomer*, Pam Reid, did most of the work by writing and typing the procedures, as well as gathering the drawings--which, by the way, were done by Earl Jungians (from photographs of John at work by Molly Lusignan). Most of my "work" consisted of scanning and re-typing Pam's work... though I do interject my two-cents here and there.

If you would like to grind, polish and figure your own mirror, I suggest [Victor's Telescope Making](#) page as well as the late Sam Brown's book , **All About Telescopes**, which may be ordered from [Orion Telescope and](#)

[Binocular Center.](#)

Introduction

The plans you will find on these pages, are, by and large, the result of years of trial and error on the part of John Dobson, one of the founders of The San Francisco Sidewalk Astronomers and a prolific telescope maker. John has, quite literally, helped thousands of people make telescopes of this design! Only in the past few years have commercial telescope manufacturers adopted the *Dobsonian* approach to make affordable, alt-azimuth Newtonian telescopes... However, the three top manufacturers (henceforth referred to as: "The Big Three"), Celestron, Meade, and Orion, continue to fall short mechanically of the simple designs found on these pages. All of The Big Three, for example, use *Melamine*; a kind of coated particle board, which is heavy, not durable, in short; not as strong or light as plywood, which, of course, *we* recommend. All of The Big Three have undersized pivot bolts, do not use *Teflon* as bearing surfaces (there is no substitute!), and have shoddy mirror cells (tailgates). The list goes on... They do look "pretty," especially in photos; I'll give them that. If you happen to own one of these scopes; you might well peruse these pages to find ways to tinker and fix up your mass-produced Dob: you can only

improve what you got! It ain't rocket science!

The designs you find on these pages are also open to improvement by *you*: the builder. Not only will you discover the ins and outs of Newtonian / Dobsonian telescope design, but you are encouraged to come up with your own modifications. We include plans to make your own Primary Mirror Cell (we call it a "Tailgate"), Secondary Diagonal Mirror Holder and "Spider," and Eyepiece Holder/Focuser. These are items even the most seasoned TM (telescope-maker) usually buys from small telescope part manufacturers: you may opt to do the same (although John's designs are perfectly functional--some ingenious--and *very* inexpensive to fabricate). Contact your local astronomy club, there are usually at least a handful of TM's that can help you out. Also, check my [Sources](#) page for materials and accessories you will need, or, might want, to purchase.

I think you will find these plans pretty clear, simple, and straightforward. If not, let me know.

Have fun!

Table of Contents:

- [Not too-tech-advice"; Materials List; Tool List; Sources List](#)
- [Overview drawing of 4.5-inch scope with Plywood Cut Pattern](#)
- [Overview drawing of](#)

[Six-inch scope with Plywood Cut Pattern](#)

- [Overview drawing of Eight-inch scope with Plywood Cut Pattern](#)
- [Overview drawing of Ten-inch scope with Plywood Cut Pattern](#)
- [Section "A": Preparing the Tube, Making "Spider"; Eyepiece tube](#)
- [Section "B": "Tailgate" \(mirror cell\) construction](#)
- [Section "C": Making the Mount](#)

Mail to:



Ray Cash

Some Not-Too-Technical Advice Before You Begin...

This Webpage contains complete instructions for constructing a Sidewalk (Dobsonian) telescope using a six, eight, or ten inch (diameter) purchased objective mirror. If you are interested in grinding and polishing your own mirror, we suggest you pick up John Dobson's video (listed under "Sources" below) as a start. Also, [Victor's Telescope Making Page](#) has step by step instructions for mirror making. **All About Telescopes**, by Sam Brown (found at [Orion Telescope and Binocular Center](#)) also has good instructions on this art.

How much is this going to cost? Well... an 8" f/7 mirror from Coulter with diagonal costs \$219.95, plus \$15.00 for shipping. If you can build an 8" scope for twice the cost of this, consider yourself lucky! You *can* buy a "Big Three" scope for only a little more; you can also buy used for less... Something else must be motivating you to "build your own." This Webpage is for you... and your daughter and/or son!

You will need to purchase one objective ("primary") mirror and one diagonal flat, ("secondary) mirror, in order to build the telescope. Mirrors may be purchased from mail-order telescope supply houses. [Coulter Optical](#) is an excellent, dependable source for good-quality, inexpensive mirrors, so we have included their address in the "Sources" list below. Tony Gondola of [BigEye Optics](#) makes custom mirrors, too.

**REMEMBER! TELESCOPE MIRRORS ARE
POWERFUL CONCENTRATORS OF LIGHT.**

**Sunlight reflected off the face of a telescope mirror can cause
BLINDNESS or START A FIRE! Always handle your
mirror indoors or in the shade! The telescope described
in these plans is for **NIGHT USE ONLY. NEVER** set
up your telescope in a location where it may be reached
by sunlight, and:**

NEVER LOOK AT THE SUN THROUGH YOUR TELESCOPE!

The plywood cutout patterns on the next few pages are for the construction of telescopes with six, eight, and ten inch objective mirrors, but you can use the same design for smaller telescopes (4.5", for example) or larger telescopes with objective mirrors of up to 15" in diameter. Just remember that the tube of your telescope needs to be at least 1-1/2" wider than the diameter of the objective mirror. Then increase (or decrease) the tube box and rocker dimensions proportionately. **THE DIAMETER OF YOUR TUBE DETERMINES ALL OTHER DIMENSIONS.**

For telescopes with mirror diameters 16" and larger, a different tube box design and mirror support system is necessary. (Again, John Dobson's telescope-making video—listed in "Sources" shows the construction of a 16" telescope with this modified tube box and support system). A more popular method of construction nowadays for large Dobs is the truss design, which allows the telescope to be "broken down" for transport and storage. See my [Vanity Page](#) for examples I have built; recommendations, and resources.

Objective and Diagonal Mirrors

What we describe as a Sidewalk Telescope, or Dobsonian Telescope, is a simple Newtonian reflecting telescope in a sturdy, wooden, alt-azimuth mount or rocker. The telescope consists of a concave (actually *parabolic*) objective (or Primary) mirror, which is mounted in the bottom of the tube. This objective gathers light from the object under observation and brings the light to a focus; forming an image of the object in what is called the *focal plane* or image plane, at the upper end of the tube.

A small, flat, front-surface mirror called the diagonal (or secondary) mirror is mounted inside the telescope tube near the front end. This mirror is mounted at a 45 degree angle to the tube's axis—hence its name. It deflects light from the objective to the side of the tube where the image may be more easily examined with an eyepiece.

The size of the diagonal mirror is dependent on the size and focal ratio of the objective mirror. So, when you order your mirrors, make sure to ask your supplier to tell you the correct size diagonal mirror to order. Specify that you will be using a low-profile focuser. To determine more accurately the size of the diagonal, peruse the following email correspondence:

balzaccom@aol.com (Paul Balzac) writes:

>By the way, I tried to find the equation you mentioned in the archives, but

>couldn't. Anyone help?

The equation is found in Richard Berry's **Build Your Own Telescope**, pgs 26-28. However, there are a couple of errors on those pages: "E" on page 27 should be changed to "D" (this makes more sense with the drawing). Also, in the final example he uses, the "6" and "8" are transposed; switch them around, in other words.

But to cut to the chase, the formula is:

$$d = df + ([D-df]/F) \times Lde$$

Where "**d**" is the minor axis of the diagonal,

"**df**" is the focal length of your primary multiplied by: the result of the amount of fully illuminated field you want divided by 57.3 (radians in a degree). In other words,

F X (x/57.3) where "**F**" is focal length and "**x**" is the amount of fully illuminated field you desire. ("**df**," is, in fact, the amount of fully illuminated field).

"**D**" is the diameter of your primary,

"**F**" is the focal length of your primary,

"**Lde**" is the distance between the diagonal and the field stop of your eyepiece.

A self-serving example: I recieved my 8" f/7.06 mirror from

Coulter yesterday. The common rule of thumb is to have a half (.5) degree of "fully illuminated field" for visual use. (But I will also plug in a .25 fully illuminated field, just to see how much smaller my diagonal will be...). The telescope will use a 10.5" outside diameter Sonotube, have a low profile focuser (say 2.125 inches high), and I will add 3/4 of an inch to be sure all my eyepieces will focus with a variety of eyeballs: So my "Lde" will be: 8.125 inches: 5.25 (radius of 10" tube) + 2.125 + .75.

"df" is then,

for a .5 degree fully illuminated field: $56.5 \times (.5/57.3) = .493$

for a .25degree fully illuminated field: $56.5 \times (.25/57.3) = .247$

So lets plug these numbers in:

The formula, again is: **$d = df + ([D-df]/F) \times Lde$** (be sure to multiply BEFORE you add)

$.493 + .133 \times 8.125 = 1.57$ inches. So, a 1.57" minor axis diagonal will fully illuminate a half a degree at the eyepiece.

$.247 + .137 \times 8.125 = 1.36$ inches. So, if I want only a .25 degree fully illuminated field to produce more contrast on the planets... I would go with a diagonal this size.

Diagonal mirrors do not come in the above sizes, of course; but one can round off--in either direction--your preference!

--Ray

A Word About Focal Length and Focal Ratio

The focal ratio of the mirror you select determines how long your telescope will be. A 10" objective mirror with an f/7 focal ratio will give you a telescope with a 70" focal length. (Multiply the "f-number" by the diameter of the objective mirror to get the focal length.) Your tube will need to be cut to the length of the focal length, so you would have a 70" long tube. An 8" objective mirror with an f/7 focal ratio would have a 56" focal length, and a 56" long tube.

(John Dobson recommends a focal ratio around f/6 or f/7)

FOCAL RATIO (f-number) x MIRROR DIAMETER = FOCAL LENGTH = LENGTH OF TUBE

When you get your mirror, the focal ratio may be exactly what you ordered, or it may be a little more, or a little less. So don't cut your tube till you receive your mirror. To measure your focal length exactly, have a friend help you: Take your mirror, a tape measure, and a piece of paper outside on any clear night and catch the light of a bright star or the Moon with your mirror and reflect it back in that direction. Using that piece of paper find where the star, or Moon forms the smallest image. Measure that distance as accurately as you can. (Instead of a piece of paper, it is often easier to reflect onto a fixed surface, such as a garage door jamb or header). Write this measurement down! This determines the length of your telescope tube, as well as where you cut a hole for your focuser. **The key thing to remember is that you want this formed image (called the *focal plane*), to hover in the same plane as the field stop of your eyepiece.** If you opt for a commercial focuser, you will undoubtedly have to cut your focuser hole in a different place than these plans call for! Do you have your eyepiece(s) yet? If that's a "yes," good: Look into your eyepiece and put your pinky finger in the other end--slowly and carefully--can you see where your finger comes into a magnified focus? Usually there is a black ring (called a *field stop*) at this point around the inside of the eyepiece; and usually this corresponds to where--on the outside of the eyepiece--the chrome barrel ends and the rest of the eyepiece body begins. This means this is where the eyepiece "bottoms out" when inserted into a commercial focuser. But, you don't want your commercial focuser to bottom out when focusing! Individual eyes and eyepieces are different! Always allow at least 3/4" "**in travel**" for your commercial focuser, when doing the arithmetic to determine where to cut your focuser hole! More is said on this subject in "Section A" of these plans online.

TUBE DIAMETER

The telescope tube should be about 2 inches wider in *outside* diameter than your objective. Therefore:

A ten-inch diameter objective mirror requires a twelve-inch outside diameter tube.

An eight-inch diameter objective mirror requires a ten-inch outside diameter tube.

A six-inch diameter objective mirror requires an eight inch outside diameter tube.

A 4.5 inch diameter objective mirror requires a 6.5 inch outside diameter tube.

Do not fret if these outside tube diameters are not *exactly* 2" bigger than your objective mirror--it is best, however, to err on the large side.

Materials List

- **Cardboard tube ("Sonotube") (1):**Construction, specifically concrete construction supply houses usually carry these tubes, which are used for forming concrete columns. Get the supply house to cut your tube rough, that is, longer than you need by, let's say, six inches or so. To "finish cut" your tube square: Tape several 8-1/2" x 11" pieces of paper together end for end--enough to wrap around the circumference of the tube, and do just that... Make the ends come together squarely; and mark the edge you want to cut. Proceed with a hand saw or Jigsaw...
- **Exterior--or interior (smoother) grade plywood:** 4' x 8' x 3/4" thick (or 1/2" thick in you are making a 4.5" scope). For an eight or ten inch telescope, one sheet will be plenty--six and 4.5" scopes use less than a half a sheet--you might be able to scrounge up scrap from your friendly local cabinetmaker. An alternative to "exterior grade plywood" would be "shop grade"; not much more expensive, a MUCH smoother finish is possible. Pre-finished plywood is fine, too.
- (Optional) **Six-Eight feet of Douglas Fir 2"X 2":** Cut these into small lengths and glue to inside of Rocker Box and Tube Box corners--this will strengthen these joints considerably.
- **Paint and painting supplies:** Flat black for inside the tube; any dark color is fine for the outside of the tube. White is not recommended--it takes longer for a white tube to cool down to ambient (outside temperature).
- **Sheet Metal Screws:** Panhead, size #8, 3/4" long. Get at least a

dozen.

- **Nails or Screws:** Assorted sizes. Hot-dipped galvanized box nails work well. Though the plans consistently refer to nailing the various parts of our scope together, using screws instead is highly recommended. 1-1/2" flat head wood screws work great. Be sure to pre-drill and countersink before driving the screws.
- **Machine Bolts (3):** Three bolts, 1" long; 3/8" in diameter.
- **Lag Screw with matching washer (1):** One lag screw, 3" long; 1/2" in diameter. (2" long if making a 4.5" scope).
- **Record (1):** One phonograph record—33-1/3 LP rpm size (A "used" record is fine.) Or visit your local cabinetmaker for some free "scrap" Plastic Laminate ("Formica" is a brand of Plastic Laminate)--you won't need much--just enough to cover the bottom of your Rocker Box (see Section "C" of these plans) and line the outside edges of your Altitude Bearings. Do not use "gloss" Plastic Laminate, however--just the rougher textured stuff. You may also want to search the internet ("google") for "kits" of Plastic Laminate and Teflon from enterprising--though often elusive--amateur telescope makers.
- **Chrome-plated Brass Tubing:** Washbasin drainline trap—1-1/2" outside diameter: We'll need two pieces: one about 1-1/2" long, for the eyepiece holder, and one about 6" long, for the aligning tube. (Available from a plumber's scrap bin.)
- **Cedar Shim Shingles:** Three pieces, about 1-1/2" to 2" wide. Shingles break easily, so it's a good idea to keep a few extra shingles on hand. They are most often sold in packages.
- **Wooden Dowel:** One piece, about 3" long. Usually sold as "closet pole" or "hand rail stock"—Approximately 1-3/4" in diameter.
- **Cardboard "Mailing" Tube:** One piece, 1-1/2" inside diameter, about 2" long (Grocery stores have this tube in the produce department—used for dispensing plastic bags.)
- **Thumbtacks (3)**
- **Leather Scrap:** Three small pieces—about 1/2" square. Old belt leather works fine.
- **Sticker or Decal (1):** About 1/2" in diameter. I like to use "hole reinforcements" stickers, for three-ring notebook paper. A "gold star" also works well. Visit your stationary store, your teacher, or raid your "junk drawer."
- **Masonite:** One rectangle of 1/8" thick Masonite board about 3" x 4" (1/4" thick is also O.K.) with a 1-1/2" hole drilled in the center; **and** three pieces about 1" square.
- **Teflon:** 7 pieces, approximately 1" x 1" square, and 1/4" thick.

Three pieces will be used for the lower Rocker Box bearings and four for the Cradle Board bearings. Try a local electronics surplus house; otherwise "google" for it. Teflon is sometimes hard to find (and more expensive than you may think)--do not accept anything else! Teflon is the key ingredient for SMOOTH movements!

- **Furring nails (4)** If you can't find furring nails, don't fret; I like to use rubber furniture glides (the kind you just nail in--this serves the same purpose as the furring nails: namely preventing our primary mirror from falling forward.
- **Glue:** White glue works fine. In addition, I like to use 100% black silicone glue on selected parts (like focuser construction and diagonal mirror to diagonal holder adhesion).
- **Telescope Objective Mirror (1):** See above "A word concerning focal ratio.." and "Sources" below.
- **Cardboard:** The back of a cardboard breakfast cereal box works nicely.
- **Telescope Diagonal Mirror (1):** Order when primary f/ratio is decided upon.
- **Eyepiece (1):** Eyepieces may be purchased from telescope supply houses (see "Sources"), or you can salvage one out of an old pair of 7 x 35 binoculars (binoculars should be labeled "fully coated optics").
- **Optional Modifications:** Commercial focusers, primary mirror cells, diagonal holders and spiders, one-power finders, additional eyepieces. . . should be factored into your plans, or can be later added as "upgrades" as you see fit.

Tools Needed

- Hammer
- Saw (Table Saw, and/or Jigsaw is/are helpful but not essential).
- Electric Drill and 1/4", 7/16", 1/2", and 3/32" Drill Bits, in particular.
- Tape Measure
- Compass
- Screwdrivers
- Nail Set
- Crescent (adjustable end) Wrench
- Awl

- Hole Cutter or 1-1/2" diameter doorhandle drill bit.
- Carpenter's Framing Square (helpful but not essential);
Combination Square
- Pencil!

SOURCES:

Sources for "Ready Made" Telescope Mirrors and Telescope Eyepieces:

- [Coulter Optical, Inc](#) -- now part of: Murnaghan Instruments

1781 Primrose Ln.

W. Palm Beach, FL

We recommend Coulter's mirrors: quality products at **very** reasonable prices. Call or write for catalog and price list.

- [BigEyeOptics](#) Tony Gondola makes custom optics.
- You may also check the "previously owned" market at:
<http://www.astromart.com/>.

Other Accessories, and Miscellaneous Parts:

- [The ATM Resource List](#). The *definitive*, up-to-date list for the Amateur Telescope Maker. If you can't find it here, I can't help you!
- Never forget to use www.google.com or some such search engine when looking to find parts!

If you want to make your own mirror, may we suggest:

● **John Dobson's Telescope-Building Video**

This 90 minute, full color video is John Dobson's personal guide to making astronomical telescopes—8 inch to 16 inch apertures and larger. Especially strong in the mirror making department and for large (read 16" Dobsonians). Free color flier available on request.

Price per tape: \$39.95

Shipping per tape: \$3.50

CA residents add \$3.40 sales tax.

Total per tape (except CA) \$43.45

Total per tape (CA only) \$46.85

Make check or money order payable to: Dobson Astro Initiatives

Remember to include your shipping address!

Mail to: Dobson Astro Initiatives

P. O. Box 460915

San Francisco, CA 94146-0915

[Victor's Telescope Making Page.](#)

○

Sources for Mirror Kits and other Mirror Making Supplies:

Willmann-Bell; P.O. Box 35025; Richmond, VA 23235

(804) 320-7016

\$1 Catalog

Newport Glass Works, LTD; 2044-D Placienta Ave; Costa Mesa,
CA 92627

(714) 642-9980

- If you can't print--for whatever reason--from these pages, I suggest you contact the [Los Angeles Sidewalk Astronomers](#): last I heard, they are still sending out hard copies for \$2.00 from this address:

The Sidewalk Astronomers
1946 Vedanta Place
Hollywood, CA. 90068

If you are requesting these plans be mailed to another country, the price may be higher.

The plans on this Webpage are much improved from the ones the LA folks send out--I recommend you try to print the plans from these pages.

I do not send any plans through the mail, nor do I have any control over those that do (concerning promptness--or anything else, that is)!

To join **The Sidewalk Astronomers** and receive our quarterly newsletter, send \$15 to:

The Sidewalk Astronomers

1946 Vedanta Place

Hollywood, CA 90068

Onwards to: [Six-inch Scope](#) Overview with
Plywood Cut Pattern

Onwards to: [Eight-inch Scope](#) Overview with
Plywood Cut Pattern

Onwards to: [Ten-inch Scope](#) Overview with
Plywood Cut Pattern

Back to: [Homepage](#), Table of Contents

E-mail: [Ray Cash](#)

4.5" Telescope Overview with Plywood Cut Pattern

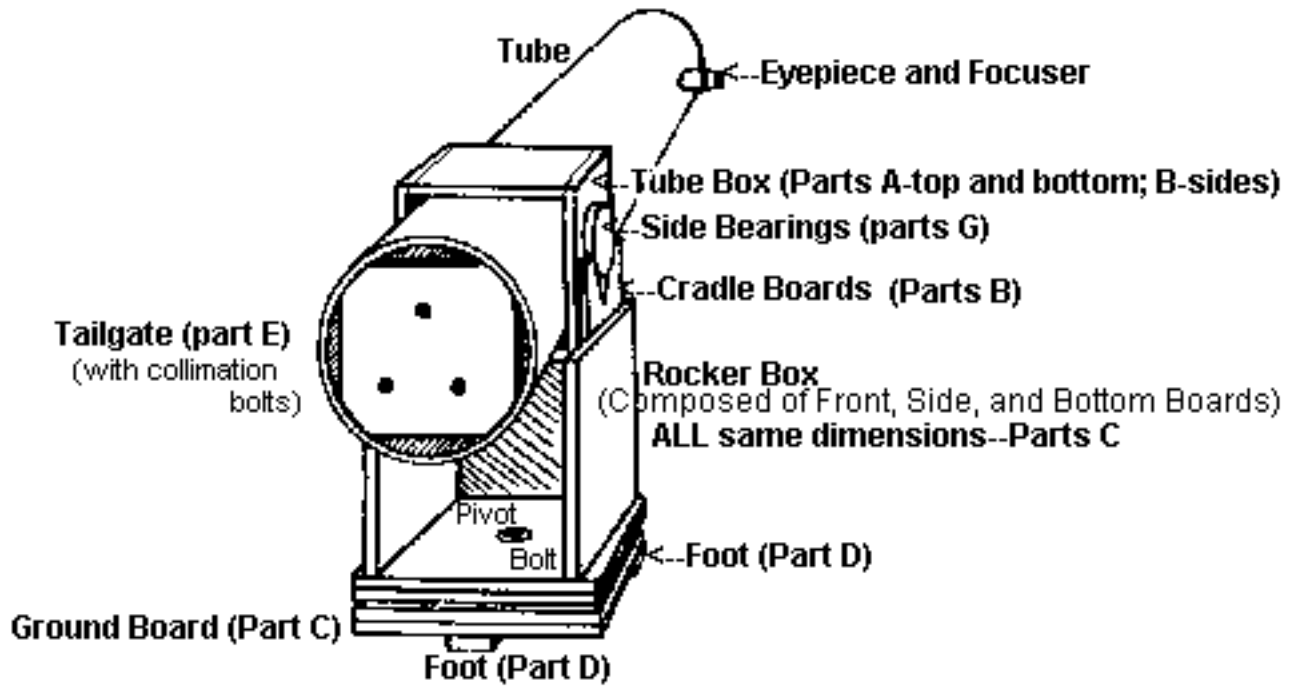

1/2" thick plywood—cut to these sizes:

Parts D (3 pieces--Feet) 1"x 1" square

Parts A (2 pieces--top and bottom of Tube Box) 6-3/4"x 6-3/4"

Part E (1 piece--tailgate) 5"x 5"

Parts B (4 pieces) (sides-Tube Box; Cradle Boards) 6-3/4"x 7-3/4"

Parts F (4 pieces) 3/4"x 4" (Mirror Blocks--*not shown*)

Parts C (7 pieces--(Rocker Box, Ground Board) 9-3/4"x 10-1/2"

Parts G (2 pieces--5" diameter circles; Altitude Bearings) Not shown below--cut from "extra."

1/2" PLYWOOD CUT PATTERN FOR A TELESCOPE WITH A 4.5" MIRROR:

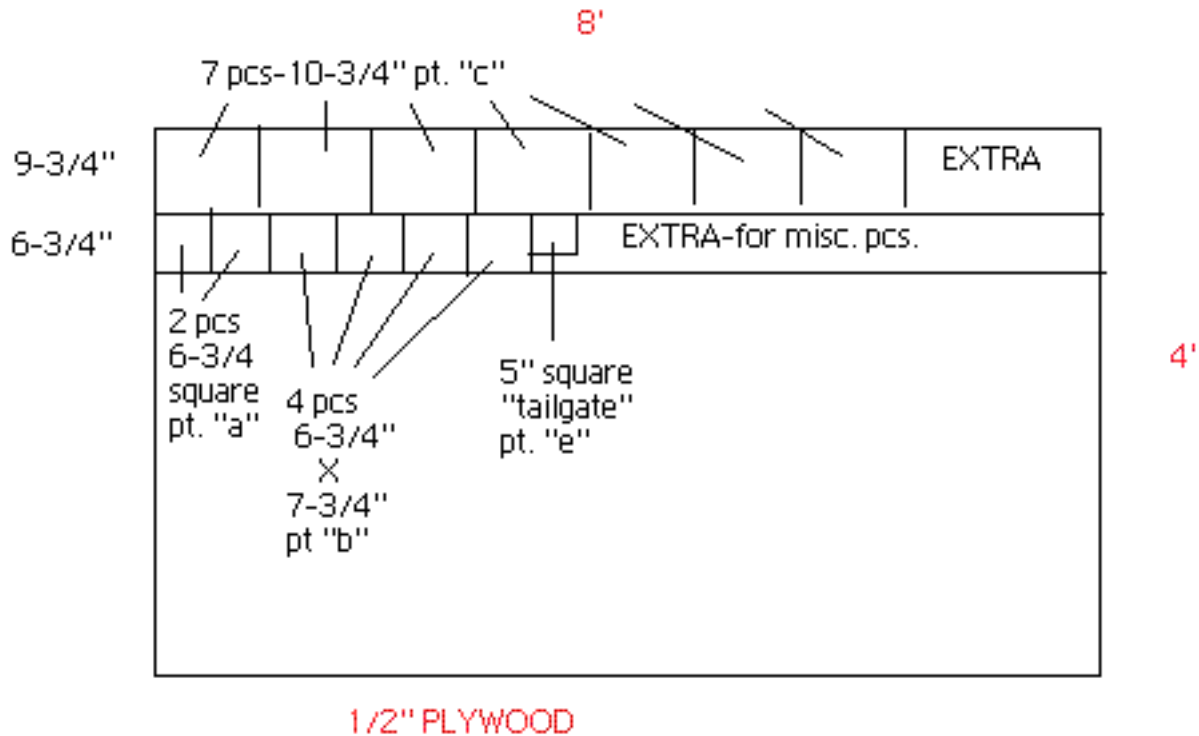

Notes:

You can make your job easier by having the lumberyard pre-cut your plywood on their panel saw. Most stores give you two free cuts and charge (50 cents?) for each additional cut. Hopefully, they can do the horizontal cuts above for you (if they can only do *vertical* cuts, modify the cut list accordingly--you have plenty of material). Then cut the pre-cut pieces into the necessary sizes at home. Note that for a 4.5-inch scope, you will be using less than a half-sheet of plywood--perhaps you and a friend can make two? Or, use scrap from your local friendly cabinetmaker?

A 4.5" telescope is going to be short. Instead of the 'normal' Ground Board above, you might think about using a three-legged stool instead (like the little girl on the front of this website) to elevate your scope and add 'cuteness.' I'd look for one (make sure it's sturdy--no wobbly legs) at garage sales and local thrift stores.

Make sure you tell the salesperson cutting the wood for you that these sizes are for the finished (cut) pieces of wood. Allowance will have to be made before cutting for the width of the saw blade !!! (You lose about 1/8" of an inch for each cut, usually.) The wood sizes given should be the actual sizes of the cut pieces of wood.

Refer to the above drawing and plywood "cut pattern" throughout the following step-by-step

instructions. Label all pieces (in pencil, chalk, or crayon) as they are cut! We will build our telescope from the "inside out," beginning with the tube.

Onwards to: [Section "A"](#): (Preparing Tube; Making "Spider"; Eyepiece Tube/Focuser)

Back to: [Homepage](#), Table of Contents

Mail to: [Ray Cash](#)

Six-inch Telescope Overview with Plywood Cut Pattern

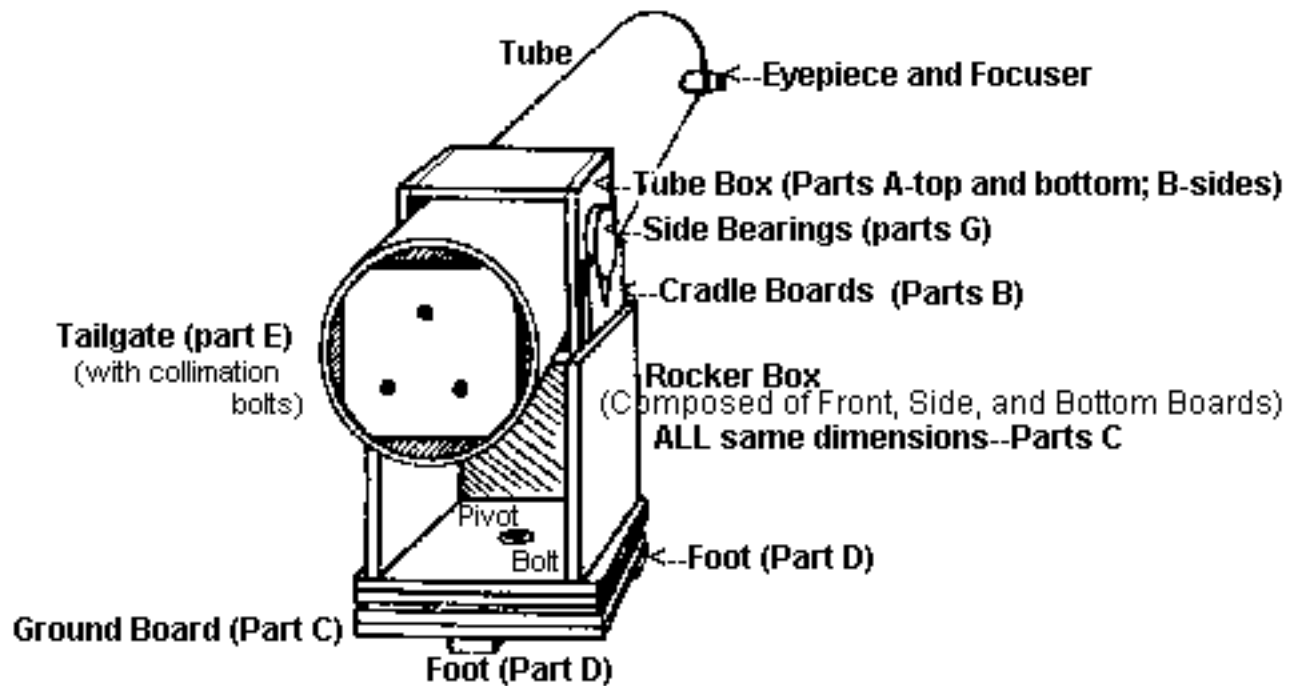

3/4" thick plywood—cut to these sizes:

Parts D (3 pieces--Feet) 1-1/2"x 1-1/2"

Parts A (2 pieces--top and bottom of Tube Box) 8-1/2"x 8-1/2"

Part E (1 piece--tailgate) 6"x 6"

Parts B (4 pieces) (sides-tube box; Cradle Boards) 8-1/2"x 10"

Parts F (4 pieces) 1"x 4" (Mirror Blocks--not shown)

Parts C (7 pieces--(Rocker Box, Ground Board) 12-1/2"x 13-3/4"

Parts G (2 pieces--5" diameter circles; Altitude Bearings) Not shown below--cut from "extra."

PLYWOOD CUT PATTERN FOR A TELESCOPE WITH A 6" MIRROR:

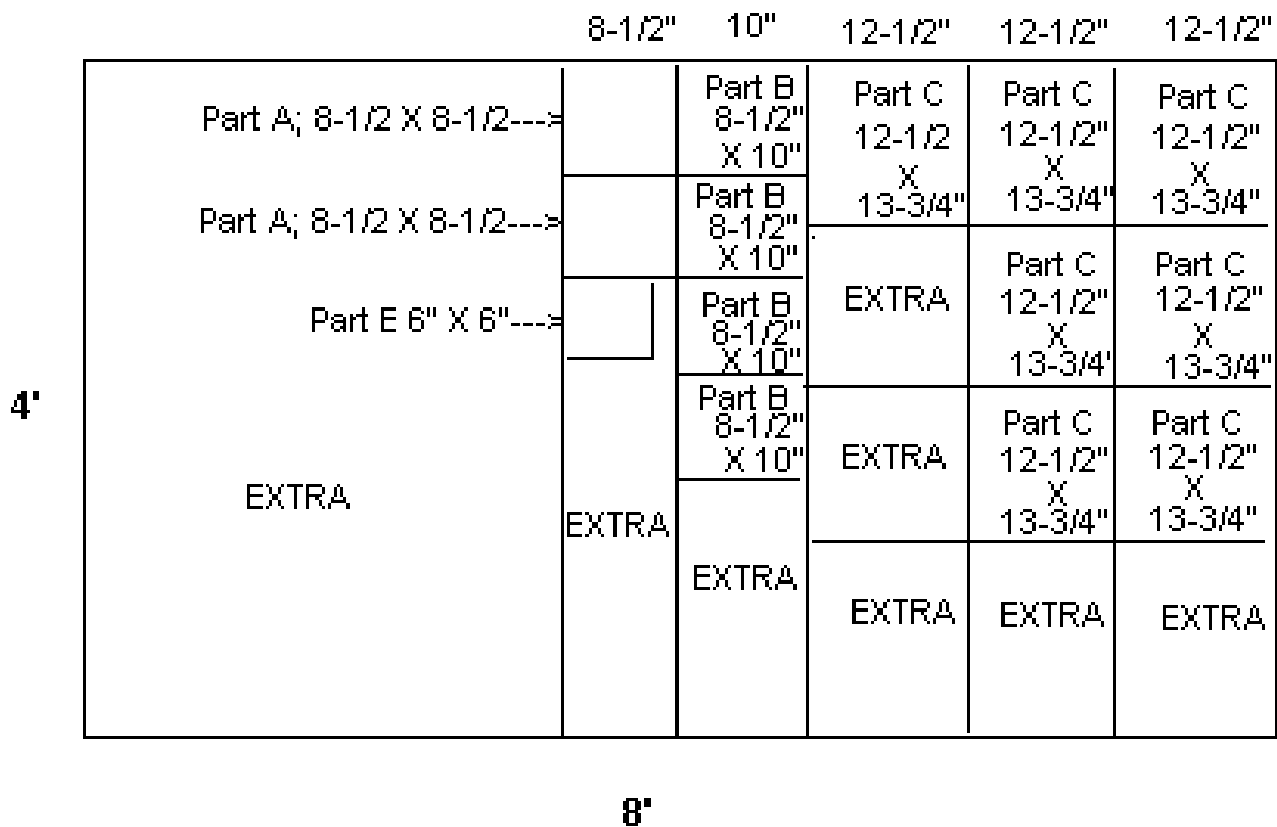
**Notes:**

You can make your job easier by having the lumberyard pre-cut your plywood on their panel saw. Most stores give you two free cuts and charge (50 cents?) for each additional cut. (They can only do the vertical cuts above.) Then cut the pre-cut pieces into the necessary sizes at home. Note that for a six-inch scope, you will be using less than a half-sheet of plywood; perhaps you and a friend can make two?

Make sure you tell the salesperson cutting the wood for you that these sizes are for the finished (cut) pieces of wood. Allowance will have to be made before cutting for the width of the saw blade !!! (You lose about 1/8" of an inch for each cut, usually.) The wood sizes given should be the actual sizes of the cut pieces of wood.

A 6" telescope is going to be short. Instead of the 'normal' Ground Board above, you might think about using a three-legged stool instead (like the little girl on the front of this website) to elevate your scope and add 'cuteness.' I'd look for one (make sure it's sturdy--no wobbly legs) at garage sales and local thrift stores.

Refer to the above drawing and plywood "cut pattern" throughout the following step-by-step instructions. Label all pieces (in pencil, chalk, or crayon) as they are cut! We will build our telescope from the "inside out," beginning with the tube.

Onwards to: [Section "A"](#): (Preparing Tube; Making "Spider"; Eyepiece Tube/Focuser)

Back to: [Homepage](#), Table of Contents

Mail to: [Ray Cash](#)

Eight-inch Telescope Overview with Plywood Cut Pattern

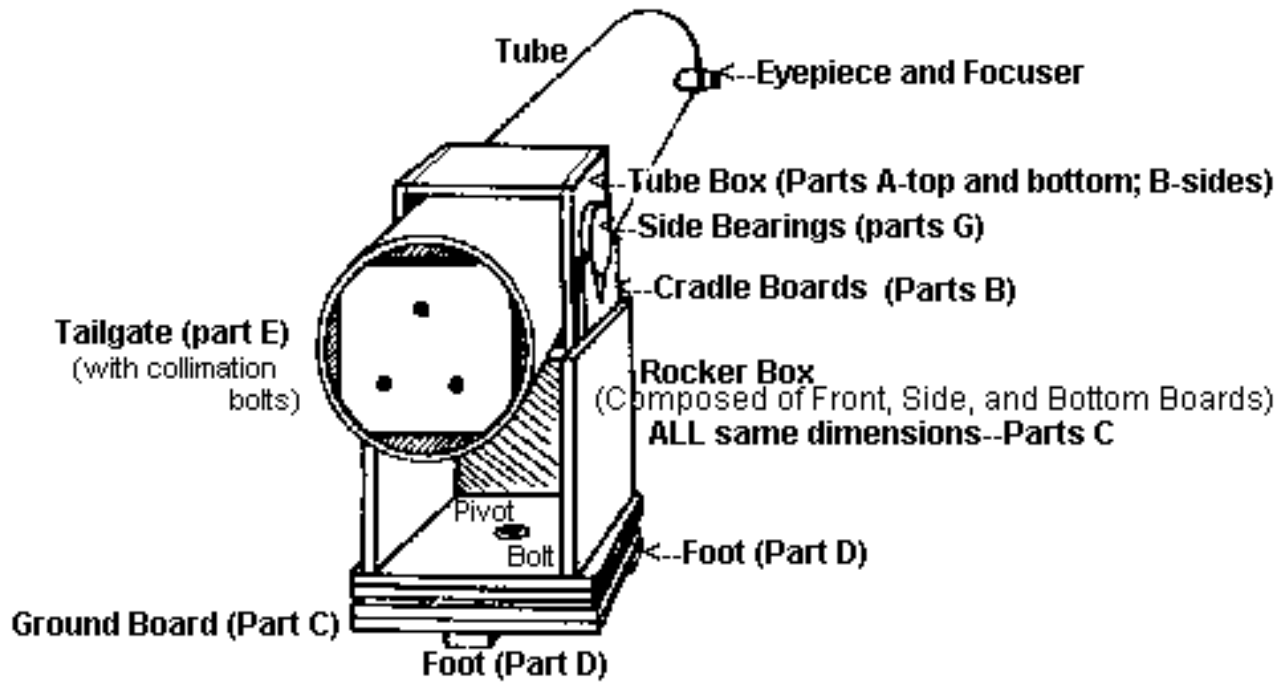

3/4" thick plywood—cut to these sizes:

Parts D (3 pieces--Feet) 2"x 2"

Parts A (2 pieces--top and bottom of Tube Box) 10-1/2"x 10-1/2"

Part E (1 piece--tailgate) 8"x 8"

Parts B (4 pieces) (sides-tube box; Cradle Boards) 10-1/2"x 12"

Parts F (4 pieces) 1"x 4" (Mirror Blocks--*not shown*)

Parts C (7 pieces--(Rocker Box, Ground Board) 14-1/2"x 15-3/4"

Parts G (2 pieces--6" diameter circles; Altitude Bearings) Not shown below--cut from "extra."

PLYWOOD CUT PATTERN FOR A TELESCOPE WITH AN 8" MIRROR:

		10-1/2"	12"	14-1/2"	14-1/2"	14-1/2"
4'	EXTRA	Part A 10-1/2" X 10-1/2"	Part B 12" X 10-1/2"	Part C 14-1/2" X 15-3/4"	Part C 14-1/2" X 15-3/4"	Part C 14-1/2" X 15-3/4"
		Part A 10-1/2" X 10-1/2"	Part B 12" X 10-1/2"			
		Part E 8"X8"	Part B 12" X 10-1/2"	EXTRA	Part C 14-1/2" X 15-3/4"	Part C 14-1/2" X 15-3/4"
			Part B 12" X 10-1/2"			
		EXTRA		EXTRA	Part C 14-1/2" X 15-3/4"	Part C 14-1/2" X 15-3/4"
			EXTRA			
8'						

Notes:

You can make your job easier by having the lumberyard pre-cut your plywood on their panel saw. Most stores give you two free cuts and charge 25c for each additional cut. (They can only do the vertical cuts above.) Then cut the pre-cut pieces into the necessary sizes at home.

Make sure you tell the salesperson cutting the wood for you that these sizes are for the finished (cut) pieces of wood. Allowance will have to be made before cutting for the width of the saw blade !!! (You lose about 1/8" of an inch for each cut, usually.) The wood sizes given should be the actual sizes of the cut pieces of wood.

Refer to the above drawing and plywood "cut pattern" throughout the following step-by-step instructions. Label all pieces (in pencil, chalk, or crayon) as they are cut! We will build our telescope from the "inside out," beginning with the tube.

Onwards to: [Section "A"](#): (Preparing Tube; Making "Spider"; Eyepiece Tube/Focuser)

Back to: [Homepage](#), Table of Contents

Mail to: [Ray Cash](#)

Ten-inch Telescope Overview with Plywood Cut Pattern

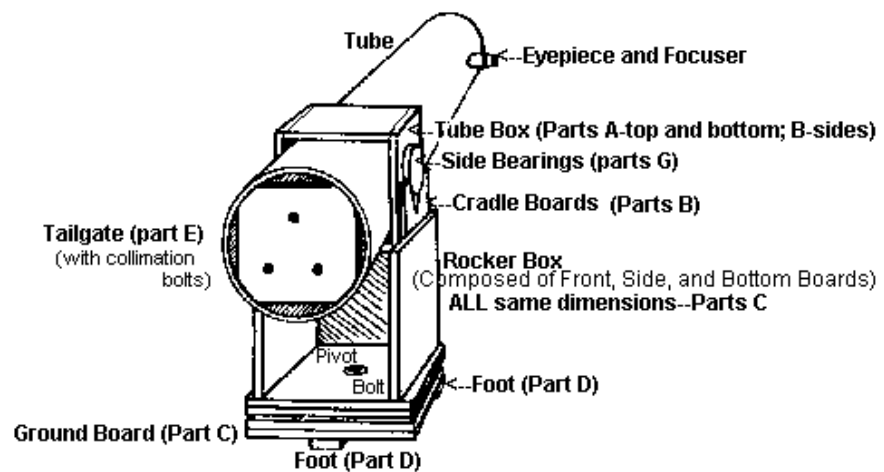

3/4" thick plywood—cut to these sizes:

Parts A (2 pieces--top and bottom of Tube Box) 12-1/2" x 12-1/2"

Parts B (4 pieces--sides of Tube box, Cradle Boards) 12-1/2" x 14"

Parts C (7 pieces--Rocker Box, Ground Board) 15-3/4" x 18"

Parts D (3 pieces--Feet) 2" x 2" **Part E** (1 piece) 10" x 10" (Tailgate)

Parts F (4 pieces) 1" x 4" (Mirror Blocks--*not shown*)

Parts G (2 pieces--Altitude Bearings--6" diameter circles). Not shown below--cut from "extra."

PLYWOOD CUT PATTERN FOR A TELESCOPE WITH A 10" MIRROR:

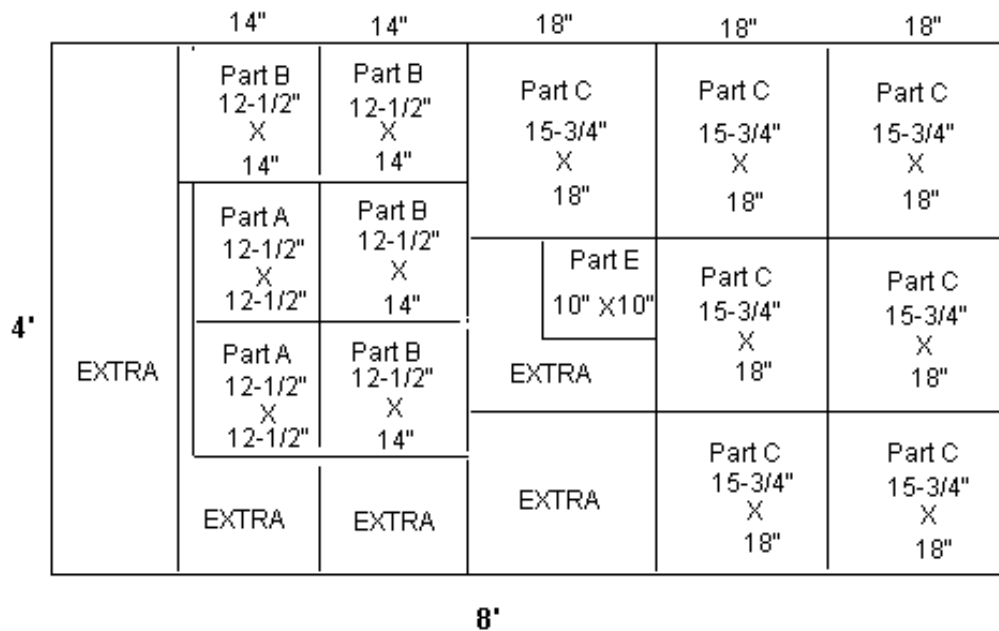

Notes:

You can make your job easier by having the lumberyard pre-cut your plywood on their panel saw. Most stores give you two free cuts and charge a nominal fee (50 cents?) for each additional cut. (They can only do the vertical cuts above). Then cut the pre-cut pieces into the necessary sizes at home.

Make sure you tell the salesperson cutting the wood for you that these sizes are for the finished (cut) pieces of wood. Allowance will have to be made before cutting for the width of the saw blade !!! (You lose about 1/8" of an inch for each cut, usually.) The wood sizes given should be the actual sizes of the cut pieces of wood.

Refer to the above drawing and plywood "cut pattern" throughout the following step-by-step instructions. Label all pieces (in pencil, chalk, or crayon) as they are cut! We will build our telescope from the "inside out," beginning with the tube.

Onwards to: [Section "A"](#): (Preparing Tube; Making "Spider"; Eyepiece Tube/Focuser)

Back to: [Homepage](#), Table of Contents

E-mail to: [Ray Cash](#)

Section "A" of Making a Dobsonian Telescope

(Preparing the Tube; Making the "Spider" and Eyepiece Holder-Focuser)

PREPARING THE TUBE

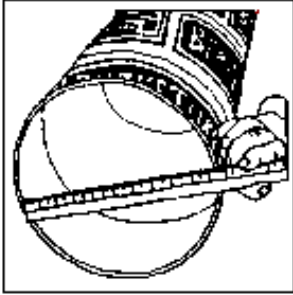

The diameter of the telescope tube should be about 2" larger in diameter than the diameter of the objective mirror

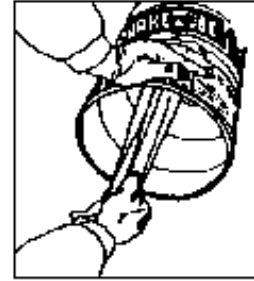

The plastic liner may be carefully peeled out of the inside of the tube. Slow, careful peeling helps keep the liner in one piece and makes it easier to remove.

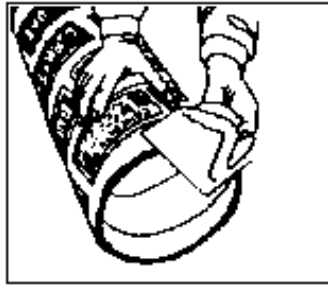

Some tubes are waxed outside. If you plan to paint the outside of the tube, a light sanding will remove some of the wax and make painting easier.

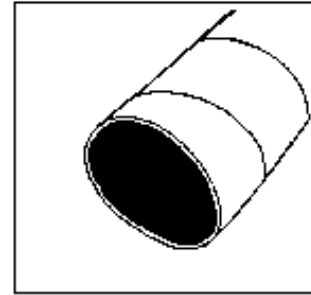

The inside of the tube may be painted black. Tape your paint brush on a broomstick handle if your tube is longer than your arm reach.

MAKING THE SECONDARY MIRROR MOUNT ("SPIDER")



Dowel (closet pole, or handrail stock) with one end cut at a 45 degree angle. Three grooves should be cut (with a thin blade) at equal (120 degree) intervals (about 1/4" deep) as

shown.

Note: How does one cut a cylinder at 45 degrees? Cut a strip of paper long enough to wrap around your "closet pole." cut both ends (of the paper strip) at 45 degrees so that you make a trapezoidal shape... wrap this piece of paper around the dowel so that the ends come together (trial and error cutting may be required here). The paper will **not** lay flat! Now trace the outline the edge of the paper makes. Cut close with a hand saw. Sand or file to line.

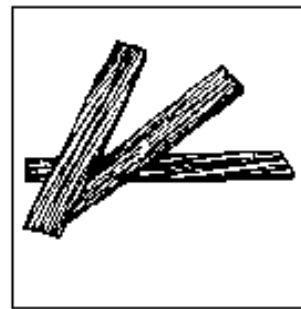

We will need three pieces of cedar shingle, each about 1 1/4" wide.

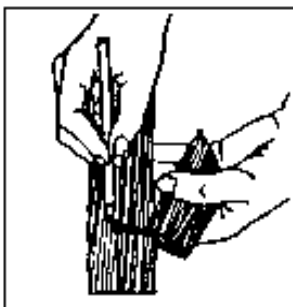

Marking the thin ends of the shingles where they fit snugly into the grooves in the dowel.

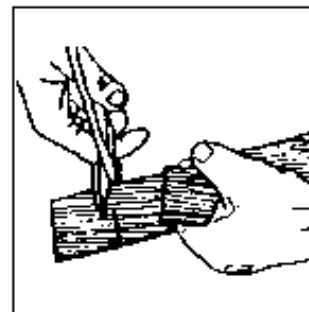

If the shingles are cut slightly concave (so they won't rock back and forth in the dowel and will fit snugly) they won't have to be glued in. Replacement will then be easy. If you do decide to glue them in, use black, 100% silicone adhesive.

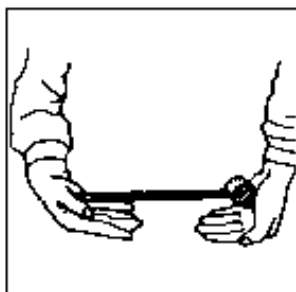

Shoving a shingle into the groove in the dowel.

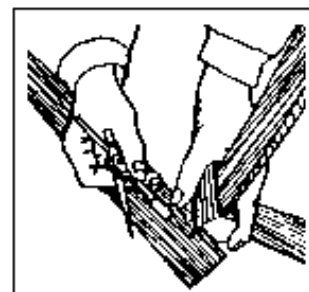

Doing the same with the other two shingles.

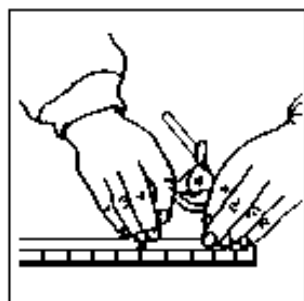

The compass should be set to the radius of the *inside* of the telescope tube.

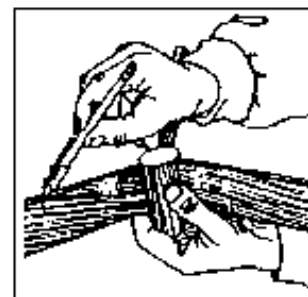

Placing the point of the compass at the center of the dowel, mark all three shingles.

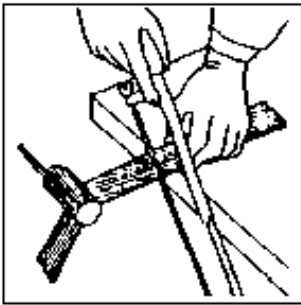

Sawing off the ends of the shingles at the marks.

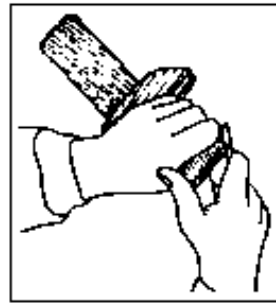

Beveling the corners so the shingles won't split when the position of the spider is adjusted in the tube.

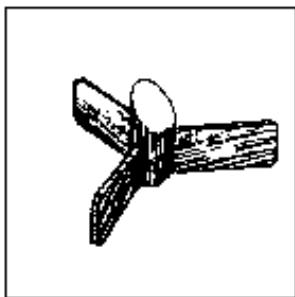

All corners beveled...

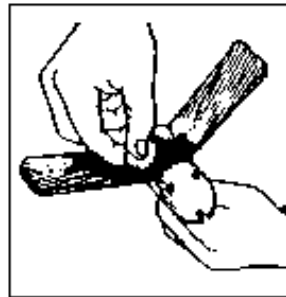

We may paint the spider black, or simply blacken the surfaces facing the eyepiece tube.

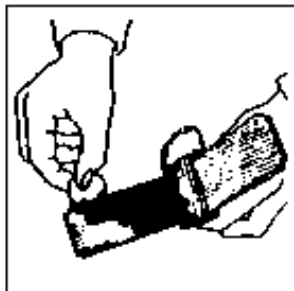

The slant-cut end should be left unpainted (to accept glue). If spray paint is used, be sure to cover the slant-cut end with masking tape while spraying

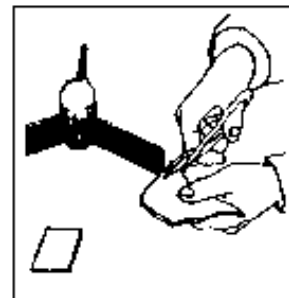

Cutting leather scrap. We will need three pieces about 1/2" square.

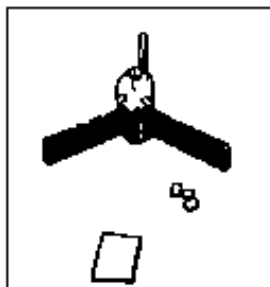

The secondary mirror (flat front-surface mirror). This mirror is also called a "diagonal." (Secondary mirrors are usually

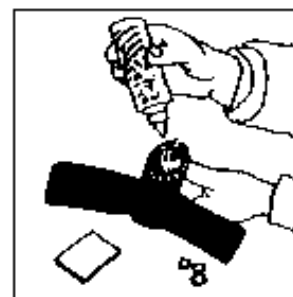

Applying glue at three points on the slant cut end of the dowel. (If masking tape was used, remove it first!). Leather pieces should be glued directly to the wood. *An alternative to leather and white glue is to use three dabs of 100% silicone adhesive--*

elliptical in shape; not rectangular like the one above).

you might want to drill three small, shallow holes in the "slant cut" to accept the silicone better.

COMPLETING THE SPIDER

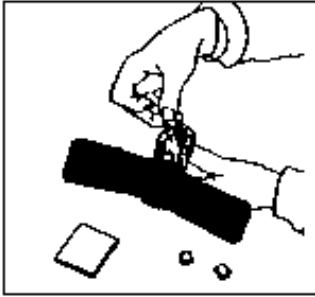

Leather pieces should be spaced evenly between the grooves. Be sure the leather gets good and wet with the glue.

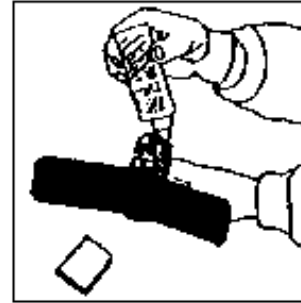

After the leather pads are glued to the dowel, we apply glue to the tops of the leather pads...

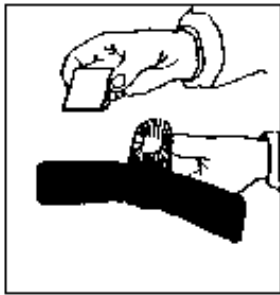

...and glue the mirror onto the pads.



Make sure the mirror is evenly centered over the dowel.

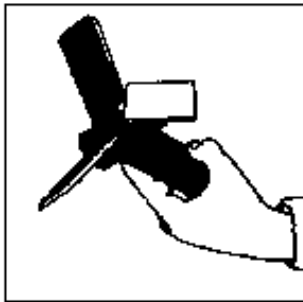

The mirror should be kept level while the glue dries.

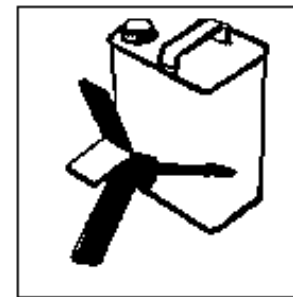

Propping up the spider while the glue sets.

MAKING AND INSTALLING THE EYEPIECE TUBE



NOTE: Above, a close-up photo of my **Dobsonian Sun scope**: An inexpensive alternative to constructing an eyepiece tube from a cardboard tube and masonite (below) is to order--and attach--a **2-inch to 1-1/4-inch adapter** from a telescope mail order house like Lumicon, Orion, or Scope City. This \$20 item is used in expensive, low-profile focusers to adapt from eyepieces with a 2" barrel to ones with the more common 1-1/4". You will have to drill a couple of holes through the metal (usually aluminum) to accept the small through bolts, and shim the flat bottom equally in two places (since you are attaching the thing to a cylindrical surface)... It adds a little more weight "up top," requires two hands to focus (one to operate the knurled stop screw, and one to push-pull focus); but you will end up with a sturdier, low-profile focuser than the one described below. Be sure to drill only a 1-1/4" hole in the tube, instead of the 1-1/2" hole as per the instructions below.

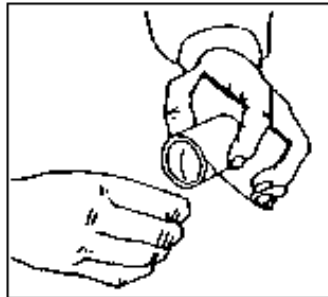

Gluing the cardboard eyepiece to a 3" x 4" piece of Masonite with a 1 1/2" hole cut in its center. Make sure to get the cardboard wet with the glue.

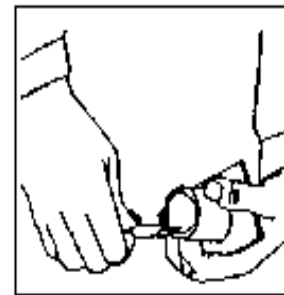

Beveling the inner edge of the tube with a pen knife so that the brass will fit in easily.

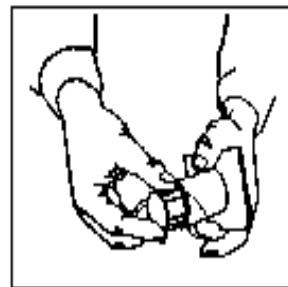
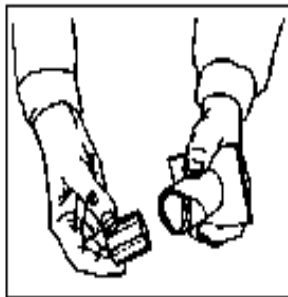

The brass tube should fit snugly inside the cardboard tube... ..and slide back and forth fairly easily.

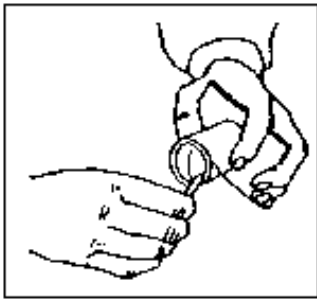

If the fit is too tight, we may peel out a thin layer of the cardboard on the inside of the eyepiece tube.

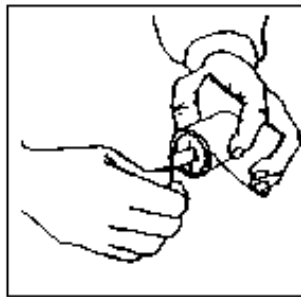

If the fit is too loose, we may glue in a strip of cardboard lengthwise down the inside of the eyepiece tube and let the end of the strip hang down over the end of the tube. (The strip should be glued down over the lip of the tube.)



Gary Morris (glmorris@jps.net) came up with an elegant solution to attain the correct amount of "focusing friction": He simply uses a hose clamp (see photo at left)... He writes that it is a onetime affair to tighten the hose clamp around the cardboard focusing tube just enough to provide the necessary friction around the sink drain tube. (This would replace the need to "peel" or "glue in a strip of cardboard" in the two previous steps)

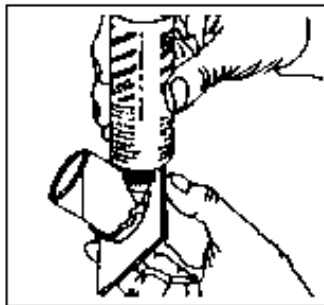

Running a thin bead of glue (100% silicone glue works well here) around the cardboard tube where it meets the Masonite.

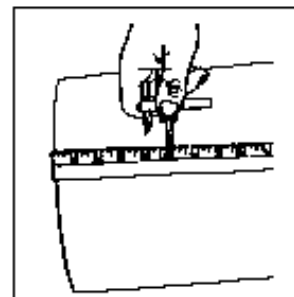

Finding the location for the eyepiece hole. See note—below:

Note: Cut the telescope tube the same length as the focal length of your mirror. Then cut the eyepiece hole back from the front end of the telescope tube by the radius of the tube. That is, for a 10" diameter tube, cut the eyepiece hole 5" from the front end; for a 12" diameter tube, cut the eyepiece hole 6" from the front end. These distances are for mirrors about 1" thick. If you have a thick mirror (i. e. 2"+) the hole should be moved up toward the front end of the tube an extra 1" to compensate. (i. e., a 12" tube with a 2" thick mirror would put the hole 5" from the front end; a 10" tube with a 2" thick mirror would put the hole 4" from the front end.

A more important Note: Now, the above *note* ONLY works if you make the homemade focuser AND follow all the details of tailgate construction, use Sonotube, etc in these plans. If you don't, you will have to do some simple arithmetic. Folks: it is extremely easy to drill your focuser hole in the wrong place! Please read the following email and my response:

> I just built a Dob with an 8" f/6 primary mirror, 48" length tube and
> centered the focuser 5" from the end of the tube. I can see the moon really
> clearly, but when I look at distant stars, I can see their light, but in the
> eyepiece, I can only see the primary mirror--the star doesn't come into
> focus. I have a Crayford R&P focuser and a zoom eyepiece (7-20MM).

Hi Daj,

This is a most common problem. I must rewrite that section on the plans!

You did what the plans told you to do; however, you used a commercial focuser, which does not have as much "in travel" as the homemade one in the plans. You need to re-position your diagonal closer to the main mirror and re-drill your focuser hole.

Here's how to figure out where EXACTLY:

Number One: Find out the exact focal length of your primary mirror (even if it is *supposed* to be 48"--for example--this may vary by an inch or more in either direction). To do this, the safest way is to bring your primary indoors, prop it up at the end of the hall, and then, with a piece of paper and a flashlight, start at about TWICE the distance of the (supposed) focal length, shine the flashlight at the primary and look for a formed image on the piece of paper (that you are holding in your other hand). **IMPORTANT:** The flashlight filament and piece of paper **MUST** be in the same plane, facing the mirror. Focus the image on the filament. Mark your floor with a piece of tape, or something. Measure carefully the distance from the face of your mirror to your mark. **DIVIDE BY TWO.** This is the focal length of your mirror. Write it down!

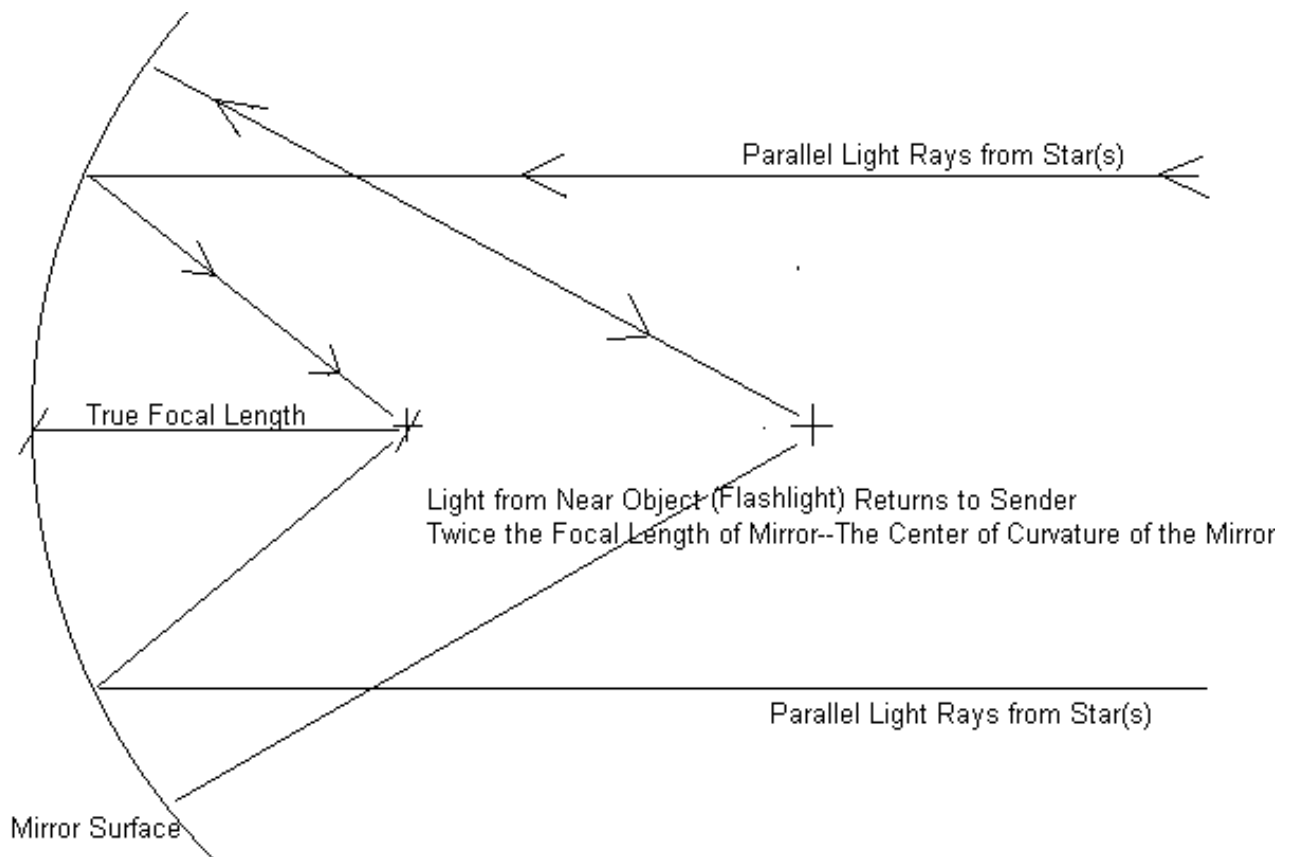

You can, of course, double check this dimension (the True Focal Length), outside at night, using the Moon or bright Jupiter as a target--don't forget to bring a friend and a tape measure to help you! And catch the image of Jupiter or the Moon bouncing back in the same direction!

Now, your telescope, when set up properly, will have a celestial image formed at the *field stop* of your eyepiece(s). Look at your eyepiece(s). Specifically, look down the "wrong end," the open end. Usually you can find a small black ring encircling the inside of your eyepiece, usually this ring corresponds to where the chrome barrel ends on the *outside* of the eyepiece, and where the eyepiece bottoms out when inserting into focuser. Find it? Now, look into your eyepiece (normally now, through the right end) and place a pinky finger in the wrong end at the field stop. See how your finger is magnified? Understand the dynamics of the telescope-to-eyepiece relationship better now? I am not familiar with zoom eyepieces; do determine where the field stop is--or its average place in relation to the outside of the eyepiece is, though. What I am trying to say is: the field stop *generally* corresponds to where the eyepiece bottoms out in the focuser, but maybe not in the case of a zoom eyepiece.

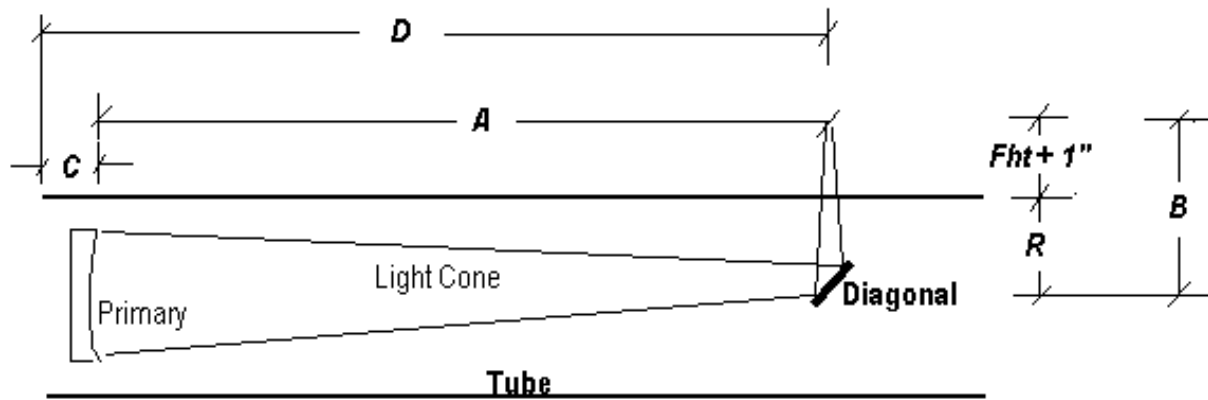

Refer to the above diagram, fill in your own values, if you will:

$A + B =$ your true focal length

$C =$ back of telescope tube to face of mirror

$D =$ back of telescope tube to center of focuser hole

$R =$ radius of tube

$Fht + 1" =$ your focuser height (fully racked in) plus one inch.

(A and/or D is what we are going to determine).

Okay: it is just simple arithmetic to determine where to drill your focuser hole and place your diagonal directly below it:

Fht + 1": Let's say you have a commercial focuser, which, when racked all the way in is 1-5/8" high (sitting 1-5/8" above the tube). First of all, you do not want your focuser racked all the way in; you need some "play"; not all eyes focus the same; not all eyepieces focus the same. Add one inch to this minimalist equation (2-5/8", in other words). You want the telescopic image to hover 2-5/8" above your tube, in other words, before being magnified by an eyepiece.

You know all the other factors: The TRUE focal length of your mirror, where the mirror face is sitting in relation to the back of your tube, and the radius of your tube.

So, as an example, let's say the true focal length of your mirror is 48".

And your mirror face is sitting 2" from the back of your tube (assuming you have 3/4" plywood tailgate + 1/4" masonite collimation pads + a 1" thick mirror = 2")

And the radius of your tube is 5".

So: add $5'' + 2\text{-}5/8'' = 7\text{-}5/8''$

Subtract $7\text{-}5/8''$ from $48'' = 40\text{-}3/8''$ This will be the distance from the face of your mirror to your focuser hole, and the diagonal.

If you add the 2" (the face of mirror to back of tube dimension), you can measure from the back of the tube $42\text{-}3/8''$

I drilled my focuser hole in the wrong place on my first homebuilt telescope; it is simple enough to fix. Did you save the piece you drilled out? Good. you can use "Bondo" (automotive body filler) to patch it back in--use masking tape to hold it in until the Bondo sets up (about ten minutes). Simply rotate your tube and redrill hole--of course you will have to reposition your diagonal, too. Another way to fix this: Move your mirror cell up or down in the Sonotube--of course, this will be easier if you keep your tube longer than (you think) necessary to begin with.

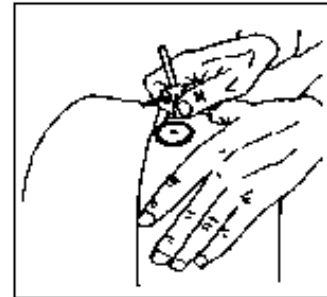
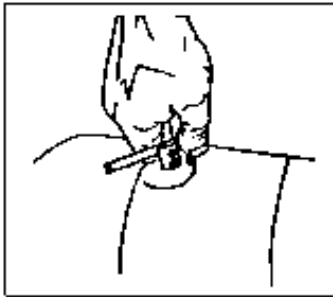

The distance we have measured is for the center of the hole. We may cut the hole to the outside diameter of the cardboard eyepiece tube.

If a hole-cutter is unavailable, a mat knife may be used.

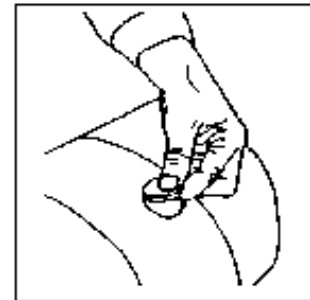
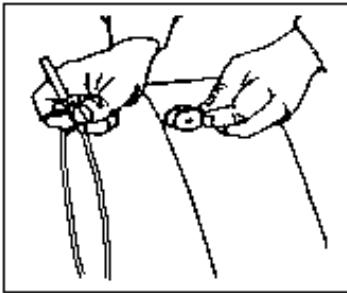

We may peel off layers of cardboard as we gradually cut through the tube.

Mission accomplished! **Hint:** *Save this piece, just in case you made a boo-boo here! It will be much easier to patch up, if necessary, with this piece still around!*

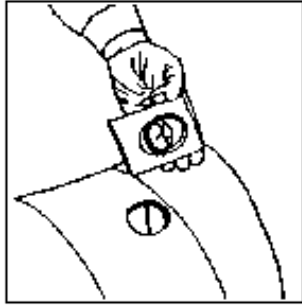

We are ready to install the eyepiece tube.

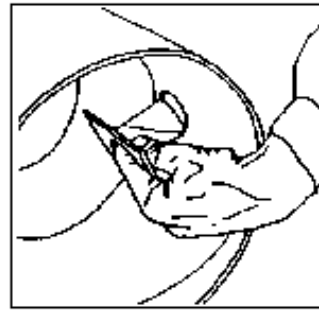

The cardboard eyepiece tube should fit snugly through the hole. If it is too tight, file or pare the hole a little bigger.

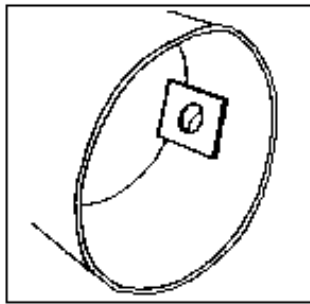

Eyepiece tube in place.

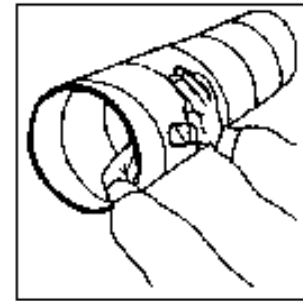

View from the outside of the telescope tube.

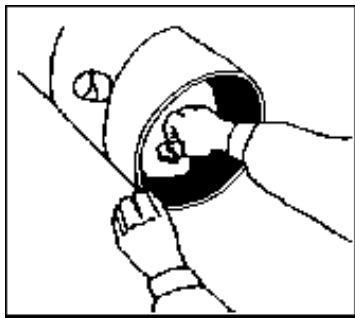

If we have not already painted the inside of the telescope tube, we now need to paint at least the section visible through the eyepiece tube black.

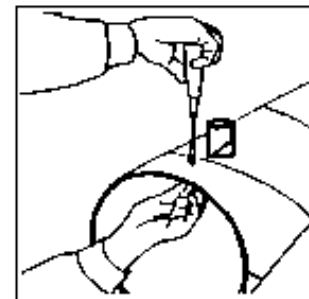

Two sheet metal screws (one on either side of the eyepiece tube) may be used to draw the Masonite rectangle snugly up against the inside of the telescope tube wall.

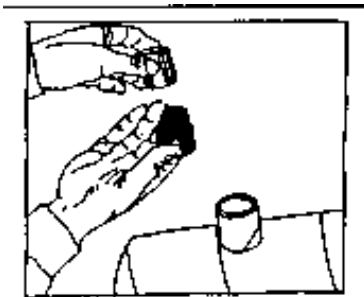

Fitting the eyepiece inside the brass tube. You can purchase an eyepiece, or salvage the eyepieces out of an old pair of binoculars.

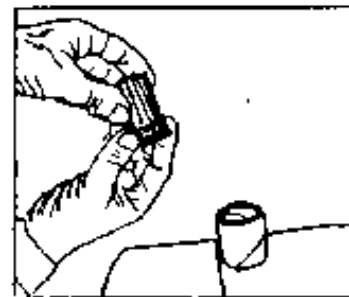

If the eyepiece is too small to fit snugly in the brass tube, wrap it in a layer of two of corrugated cardboard.



Adjust the amount of cardboard as needed so that the fit of the eyepiece in the brass tube is snug.

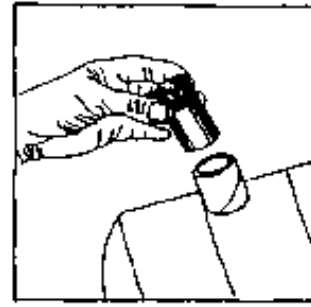

The eyepiece is ready for use!

Please Note: It is very easy to whack your eyepiece holder as you move your telescope tube around: Be especially mindful of doorjambes and car loading/unloading!

INSTALLATION & ADJUSTMENT OF THE SPIDER

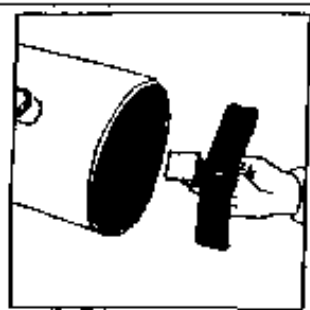

Trying out the fit of the spider in the telescope tube.



Adjust the spider so that the diagonal mirror is in front of the eyepiece hole. (The diagonal mirror should be facing the hole).

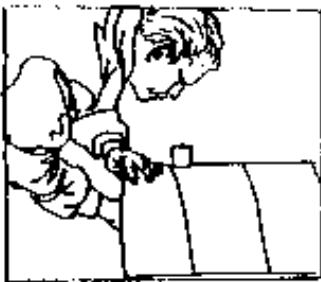

When we look through the eyepiece hole we should be able to see the reflection of the (open) bottom end of the telescope tube in the diagonal mirror.

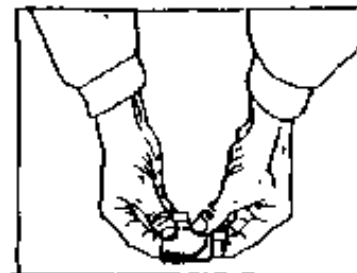

If the fit of the spider is too loose, we may tighten the fit with cardboard folded to the necessary thickness...



Fitting cardboard under one shingle (the shingle opposite the eyepiece hole). Readjust the spider as needed after fitting the cardboard.

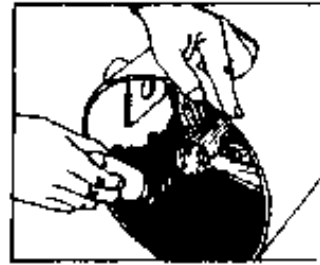

When installed, the whole objective mirror will need to be visible in the diagonal when we look into the eyepiece hole. Do not glue the spider to the tube until final adjustments are made on the alignment.

Onwards to: [Section "B"](#) (Tailgate; mirror cell construction)

Back to: [Homepage](#), Table of Contents

E-mail: [Ray Cash](#)

Section "B" of Making a Dobsonian Telescope

MAKING THE TAILGATE (Mirror Cell)

*(Please Note: Many find the following simple mirror cell too simple. . .
The solution is to purchase a commercial spring-loaded mirror cell. Google for options!)*

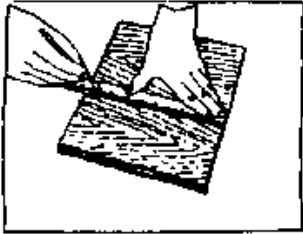

The tailgate should be a square with the same width as the objective mirror. (e. g. a 10" mirror in a 12" tube gets a 10" square tailgate--you will soon "lop off" the corners.)

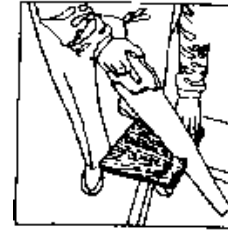

Cutting out the tailgate.

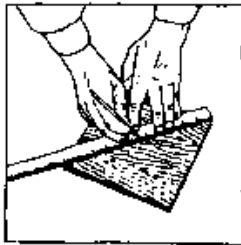

Finding the center of the tailgate.

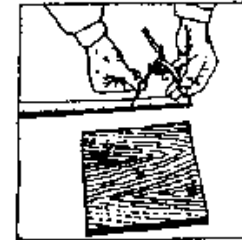

Set the compass for the radius OF THE INSIDE OF THE TUBE. (Not the radius of the mirror.)

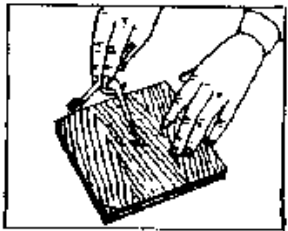

Drawing a circle with the compass point at the center of the tailgate. Only the very corners of the wood will be touched by the pencil.

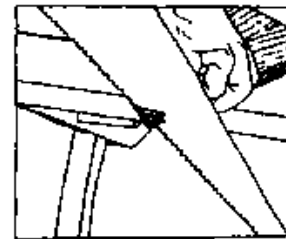

Sawing off the corners of the tailgate at the pencil marks. Now the tailgate should fit inside the telescope tube. (Plane or sand to fit if necessary.)

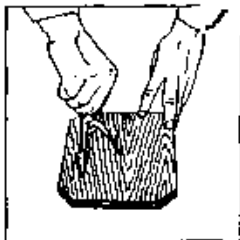

Drawing a second circle for the placement of the tailgate bolts.

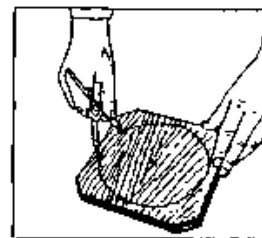

This circle should be 2" smaller than the diameter of the objective mirror. (e. g. for a 10" mirror, we need an 8" diameter circle.)



Dividing the circle into six equal segments (the radius of the circle you just drew).



Marking the circle at each of the six points.

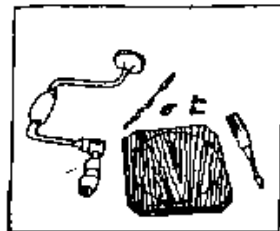

Of the six marks on the circle, we choose three (every other one) for our equilateral triangle. *We want two of our three marks to be towards two of our "cut-off" corners.* One bolt is placed at each of the three angles.

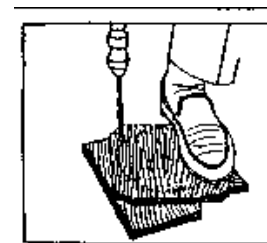

Drilling bolt holes. (A power drill also works well, if available).

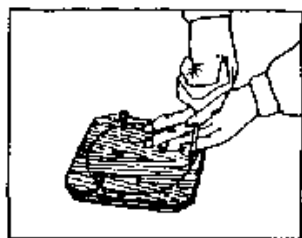

The bolt holes should be one sixteenth of an inch smaller than the bolts (5/16"), so that the bolts will fit snugly.



Screwing in the tailgate bolts. The bolts should be threaded right through the wood.

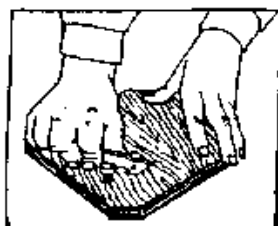

The bolts should be quite snug and difficult to turn.



The view from the other side: tailgate bolts poking through the wood.

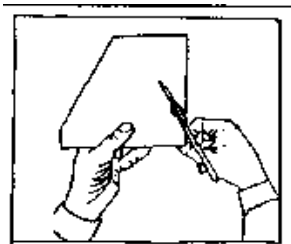

Now we cut a piece of thin (e. g. cereal box) cardboard into a triangle which will cover the protruding bolts.

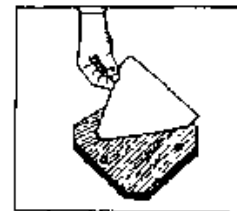

The cardboard should cover all three of the bolts where they come through the wood.

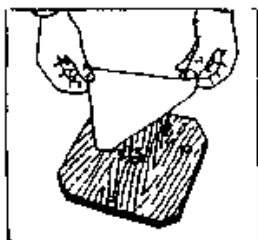

Gluing the cardboard in place.
(Apply glue at the center of the cardboard only!!!)

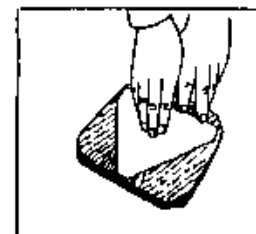

Letting the glue set.

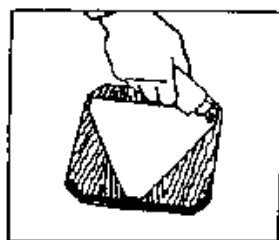

Now we apply glue to the cardboard at the three places where the bolts poke through the wood...

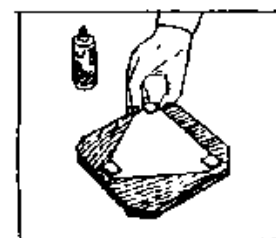

...and glue the squares of Masonite (about 1" square) onto the cardboard directly over the protruding bolts.

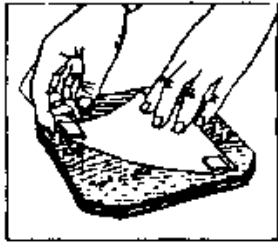

This cardboard protects the mirror from the tailgate bolts if the telescope is dropped on its end. This cardboard must be floppy so as to allow alignment of the objective.

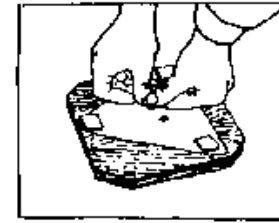

Fixing the position of the cardboard with two thumbtacks. (Double-check first to make sure each Masonite square covers its protruding bolt!)

MOUNTING THE MIRROR IN THE TUBE

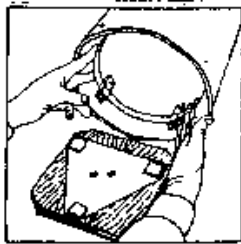

We use four mounting blocks to mount the mirror in the telescope tube. When the mirror is installed, it should rest on the two bottom blocks, but clear the two top blocks. Furring nails, or rubber furniture glides, are placed at the ends of each of the mounting blocks to prevent the mirror from rolling out of the front end of the tube. After you have installed the mounting blocks and the mirror, check to make sure that the mirror cannot get past the furring nails, or furniture glides. If it does, you will have to increase the height of the mounting blocks as necessary.

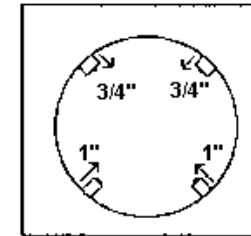

The mirror mounting blocks are designated PART F in the plywood cutting plans.

The mounting blocks are screwed in place inside the telescope tube. The mirror sits on the two bottom blocks and should just clear the top blocks—under no circumstances should the mirror be pinched or squeezed between the blocks.

If the blocks are cut from 3/4" plywood and are 1" wide (they should be about 4" long), we will probably have to place two blocks with the 3/4" side "up" and two blocks with the 1" side "up" in order for the mirror to fit nicely (see diagram above).

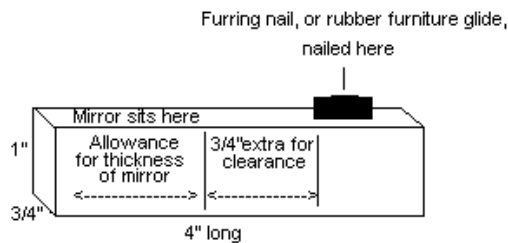

A furring nail (or rubber furniture glide), is hammered into each block before the blocks are screwed into the telescope tube. The furring nails prevent the mirror from rolling out the front end of the telescope tube. To determine the placement of the furring nail, allow room on the block for the width of the mirror, plus an extra 3/4" for clearance. Please note: the drawing at left is for bottom blocks (1" high); for top blocks, they should be turned 90-degrees and only be 3/4" high before nailing furring nails or rubber furniture glides on.

Wood Mounting Block

INSTALLING THE MOUNTING BLOCKS

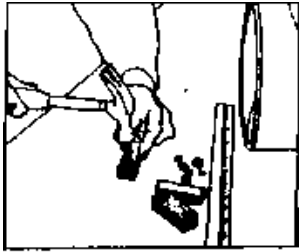

A furring nail should be hammered into one end of each of the mounting blocks (allow necessary clearance—see previous figure above) before the blocks are screwed into the tube.

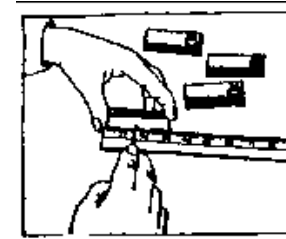

Preparing the blocks for installation in the telescope tube. A pilot hole for the screw may be made in each block (on the side of the block without the furring nail). 2" from the end (i. e. the end without the furring nail).

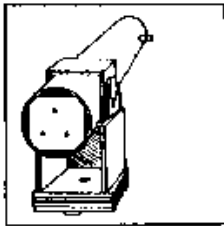

It is convenient to have the eyepiece hole on either the right side (shown), or the left side, depending on which of your eyes is "dominant." To determine which eye is dominant, simply hold your fist up to your eye and imagine this to be an eyepiece--which eye do you instinctively use? If it is your left eye, mount your tailgate so the eyepiece hole is on the right; vice-versa if it is the right eye. This will be more comfortable if, in the future, you decide to mount a Telrad, Quikfinder (1X finding aids), or a finder scope. The eyepiece may be positioned horizontal (as depicted), or canted up about 30-45-degrees; the latter helps insure your eyepiece doesn't fall out accidentally, and usually lends itself to more comfortable viewing.

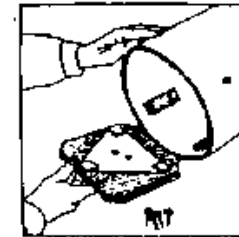

Mounting blocks are attached to the tube with screws so that the four corners of the tailgate (when installed) will butt up against all four blocks. Please see previous note to determine where you want your eyepiece to be positioned. You also want two collimating bolts to be at the bottom; one on top--as illustrated above and previous.

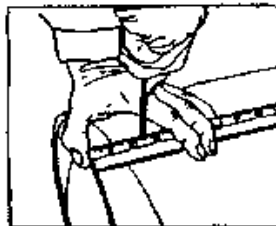

Preparing to screw the mounting blocks into the tube. Pilot holes for each of the screws may be made in the main tube 3" from the rear end.

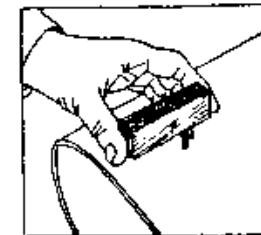

This gives the ends of the blocks 1" clearance from the rear end of the telescope tube, and leaves adequate space for installing the tailgate.

INSTALLING THE TAILGATE

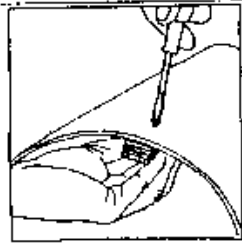

Screwing one of the mounting blocks securely in place.

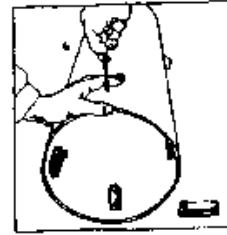

Screwing in the other three blocks.



All four blocks are installed. Time to put in the tailgate.



The tailgate should butt snugly against all four blocks so that it won't rock when pushed alternately on opposite corners. If it does rock; try gluing cardboard to the end of the offending block.

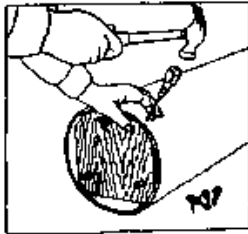

Making pilot holes for the four tailgate screws. The screws go through the cardboard tube and into the wood.



Screwing in the tailgate at all four corners.
(Check the fit of the tailgate before installing the mirror).

INSTALLING THE MIRROR

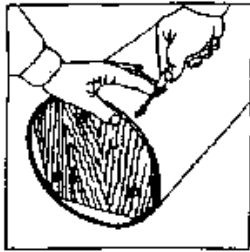

When the tailgate is snug, we are ready to install the mirror.
(Of course, you will have to remove the tailgate again).

CAUTION: HANDLE YOUR MIRROR INDOORS OR IN THE SHADE!!!

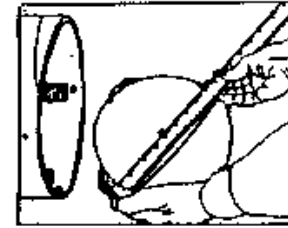

Carefully place a sticker or decal at the exact center of the mirror. This sticker will be used later to align both the diagonal mirror and the objective mirror.

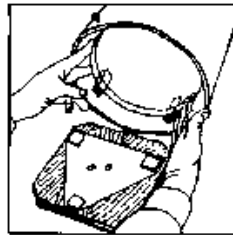

Installing the mirror--very carefully!

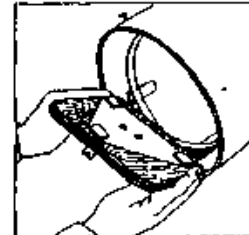

After installing the mirror, close up the tailgate...

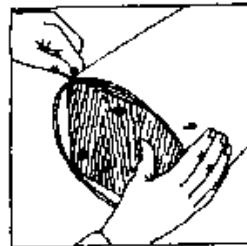

...and screw the tailgate in.

Now we are ready to build the tube box and rocker.

Onwards to: [Section "C"](#) (Making the Mount)

Back to: [Homepage](#), Table of Contents

E-mail to: [Ray Cash](#)

Section "C" of: Making a Dobsonian Telescope

MAKING THE MOUNT

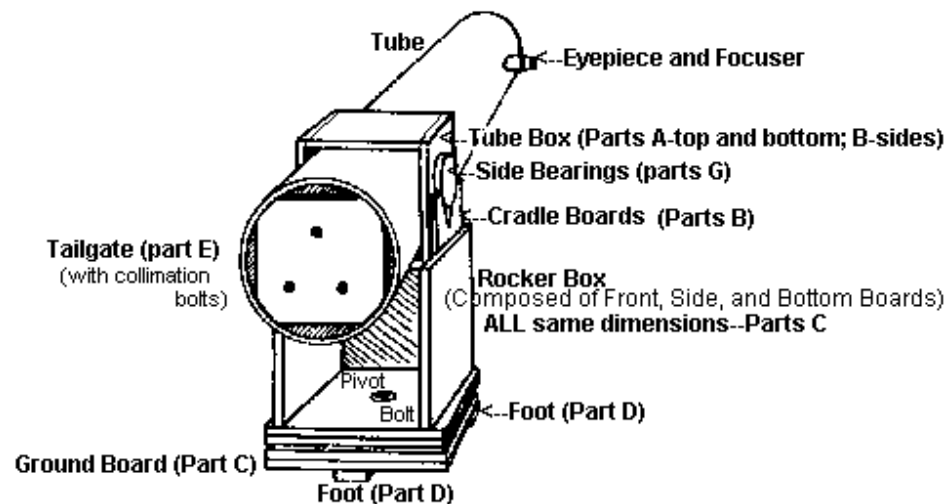

The completed telescope

Assembling the Tube Box

1) Glue and nail the **Tube Box** together as shown.

2) Nail the two **Side Bearings** (circles) onto the sides of the **Tube Box** as shown. **Side Bearings** should be centered. Side bearings do not have to be 6" in diameter, by the way. Many folks use circular plumbing parts, which are much smaller. You may also want to put side bearings on ALL four surfaces--this way, you can rotate your scope 90-degrees for a more comfortable viewing position when desired--especially useful if you have a short (fast focal ratio) tube scope. You might opt to have your circles cut out with a router, by your local, friendly cabinetmaker. While, he/she is at it, ask him to band the edge with plastic laminate ("Formica"); use a screw and a finish washer at the plastic joint. When mounting your side bearings, make sure this screw and washer is mounted at the top when your telescope is pointed at 45 degrees above the horizon ("X"--in the illustration at right)--this insures that they will not interfere with your Teflon bearing surfaces.

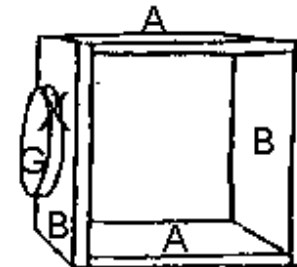

3) Slide the telescope tube into the **Tube Box**. If the tube is too loose in the **Tube Box**, the fit can be tightened by placing a board or boards (Masonite works well) of the necessary thickness between the tube and the **Tube Box**. After the telescope is fully assembled and balanced, a screw can be screwed through the tube into the **Tube Box** from inside the tube to make sure the tube "stays put."

VERY IMPORTANT NOTE!

Read This Before Assembling The Rocker Box On The Next Page!

u u u

POSITIONING THE SIDE BOARDS

One of the TRICKIEST parts of assembling the **Rocker Box** is getting the right amount of clearance between the **Side Boards**. This is how to determine the clearance:

- 1) Measure the width of the **Tube Box**—but do NOT include the width of the **Side Bearings** (circles) in this measurement!
- 2) The **Tube Box** needs to fit inside the **Rocker Box**, with clearance for two **Cradle Boards**, i.e., Part B (in which the **Side Bearings** sit): PLUS an extra 1/8" clearance on each side.

FORMULA FOR DETERMINING THE SPACE BETWEEN THE SIDE BOARDS:

Width of Tube Box PLUS width of (2) 3/4" (or 1/2" with a 4.5" scope) Cradle Boards PLUS 1/4" clearance.

Example # 1 (for 4.5" Dob using 1/2" Ply)	Example # 2 (for 6" Dob using 3/4" Ply)
Tube Box.....7-3/4" Square	Tube Box.....10" Square
Plus 1/2" each for 2 Cradle boards1"	Plus 3/4" each for 2 Cradle boards1-1/2"
Plus 1/4" clearance (1/8" on each side).....1/4"	Plus 1/4" clearance (1/8" on each side).....1/4"
Distance between Side Boards =.....9"	Distance between Side Boards =.....11-3/4"

Example #3 (for 8" Dob using 3/4" Ply)	Example #4 (for 10" Dob using 3/4" Ply)
Tube Box 12" Square	Tube Box..... 14" Square
Plus 3/4" each for 2 Cradle Boards..... 1-1/2"	Plus 3/4" each for 2 Cradle Boards..... 1-1/2"
Plus 1/4" clearance (1/8" each side).....1/4"	Plus 1/4" clearance (1/8" each side).....1/4"
Distance Between Side Boards =..... 13-3/4"	Distance Between Side Boards =..... 15-3/4"

NOTE: All of the plywood sizes for the Tube Box and Rocker Box of a Dobsonian telescope are determined by the outside diameter of the tube. By using the above formula/arithmetic, you can calculate the sizes of the plywood for any size Dobsonian telescope.

ASSEMBLING THE ROCKER BOX

- 1) Glue and nail two PART C pieces together for the **Bottom Board**, this will be the base of your soon-to-be **Rocker Box**. (i. e. make it **DOUBLE THICKNESS** for added stability and extra "meat" for the lag screw--your pivot bolt--to rotate around).

- 2) Glue and nail the bottom ends of the **Side Boards** (Part C) to the top surface of the **Bottom Board** the correct distance apart (use formula above for correct spacing between **Side Boards**). Be sure that the front edges of the **Side Boards** are even with the front edge of the **Bottom Board**, because we will need an even surface on which to glue and nail the **Front Board**.

- (**Note:** The **Side Boards** are attached to the top surface of the **Bottom Board** "long side" up. The **Front Board** is attached to the front edge of the **Bottom Board** "short side" up and should cover the front edge of the **Bottom Board**.)

- 3) After the **Side Boards** are glued and nailed, set the **Front Board** in place to see how far up the front edges the glue needs to go. Then glue and nail the **Front Board** to the front edge of the **Bottom Board**. Check to make sure that the spacing between the **Side Boards** is correct (see above) before nailing the **Front Board** to them.

- 4) Glue and nail together the two remaining Part C pieces to make the **Ground Board**. (As with the **Bottom Board**, the wood is doubled for added stability and extra "meat" to which our very important lag screw will be affixed to).

As I say elsewhere, if you are making a 4.5" or 6" telescope the overall height is going to be short. Instead of the 'normal' Ground Board described here, you might think about using a three-legged stool instead (like the little girl on the front of this website) to elevate your scope and add 'cuteness.' I'd look for one (make sure it's sturdy--no wobbly legs--and with a wood top) at garage sales and local thrift stores.

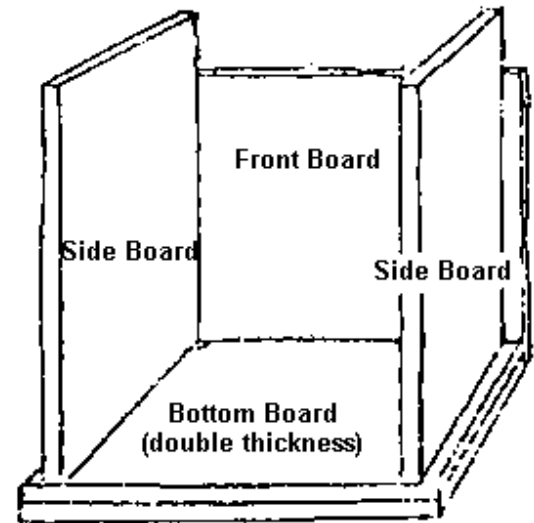

The Rocker Box

- 5) Find and mark the center of the **Ground Board**. Then turn the **Ground Board** upside down and glue and nail the three **Feet** (part

D—three pieces) in place as shown (the TWO feet go in FRONT--on one of the longer edges, that is):

Front edge of **Ground Board** (upside down, "plan view")--one foot at each corner:



Back edge of **Ground Board** with foot centered

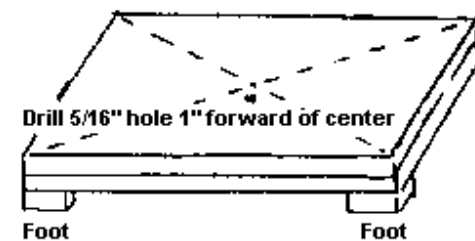

The Ground Board

(double thickness)

6) Now turn the **Ground Board** right-side-up. Make a mark one inch forward (toward the TWO front feet) of the center. (*Do NOT let this 1" forward confuse you; this is just an approximation of the center of the triangle the three feet make. The three sides of this triangle are not equal--the front side of the triangle--the one with a foot in each corner is shorter than the other two sides pointing back to the other foot. A more accurate way to determine this center is to find the midpoint of each side of the triangle and draw a line at a right angle to each side toward the center; the intersection of the three lines is the true center of the triangle formed by the feet.*) Drill a hole on this mark for the lag screw. This hole should be three sixteenths of an inch smaller in diameter than the lag screw (5/16") to insure a tight, threaded fit. Be careful to drill this hole as square as possible (have a friend "sight" for you as you drill).

7) Turn the **Rocker Box** upside down. Place the **Ground Board** (which you just drilled a 5/16" hole near the center of) on top of the upside down **Rocker Box**. Orient so all sides are flush (even) with each other. (Actually, the **Front Board** will "hang over" the **Ground Board** 3/4"--"split the difference," if you like). Using your 5/16" drill bit and the **Ground Board** as a *template*, drill through the bottom of the **Rocker Box** (the **Bottom Board**). Now use a 1/2" drill bit to make this hole (the one in the **Rocker Box** ONLY) larger--1/2" is the diameter of your lag screw/pivot bolt. Always drill as square as possible--you might have a friend "sight" for you as you drill. Leave the **Ground Board's** hole at 5/16"!

Note: The hole in the LP record will not be big enough for the lag screw to fit through, so you will have to enlarge it with the drill--might as well do it now while you have the 1/2" drill bit in the drill!. Use the same bit you used to drill the hole in the **Rocker Box**, i. e., the same size as the diameter of the lag screw (1/2"). (CAUTION: Have someone hold down the record for you while you drill it or it will madly ride up on the bit). Note: A 12" diameter LP will have to be trimmed to a smaller diameter (~9-3/4") for a 4.5" Dob, for the larger size Dobs, a 12" LP will be fine.

8) On the **Ground Board** (which should be right side up, i. e. with the feet on the ground), nail or screw three squares of Teflon in a circle at three angles of an equilateral triangle about half way between the "center" hole and the feet. (The phonograph record will ride on these Teflon squares, so check to make sure the squares don't extend past the edge of the record).

Note: Plastic Laminate ("Formica" is a brand of Plastic Laminate) can be used instead of an LP record, and may be easier to find nowadays--try your local cabinetmaker--they usually have tons of scrap they will let you have for free. **Do not** use the "gloss" kind of PL, the rougher the surface, the less the friction--Wilson Art's *Ebony Star* is generally considered the best. Some **Home Depots** sells *Ebony Star* in less-than-full-sheet amounts. Plastic Laminate can be cut with tin snips and then filed flush if you do not have access to a router. Glue your Plastic Laminate down with contact cement like 3M's *Spray90*. Of course, if your plastic laminate is cut circular (like an LP record) there is no need to glue it to the **Bottom Board** (the base of the **Rocker Box**).

Use finish nails (small heads) to nail the Teflon onto the **Ground Board**, and use a nail set to inset the nail heads. If you opt to attach the Teflon with screws, use only flat-headed wood screws and countersink the screws so the screw head is "buried" beneath the top surface of the Teflon. (The record must ride smoothly on the Teflon and not be scraped by the nail or screw heads).

9) Now we are ready to assemble the **Rocker Box**, LP (or Plastic Laminate), and **Ground Board** in a sandwich like manner: Place the record (or Plastic Laminate) over the **Ground Board** and the **Rocker Box** over the record on the **Ground Board**, so that all the holes are lined up. Insert the lag screw (with its washer) and screw it in. (Be vigilant as you do this to make sure that the lag screw goes in straight, not at an angle). Tighten the screw until it is snug and then back off a bit--an 1/8 of a turn, let's say. The **Rocker Box** should swivel smoothly on the **Ground Board**. Voila: Our azimuth motion!

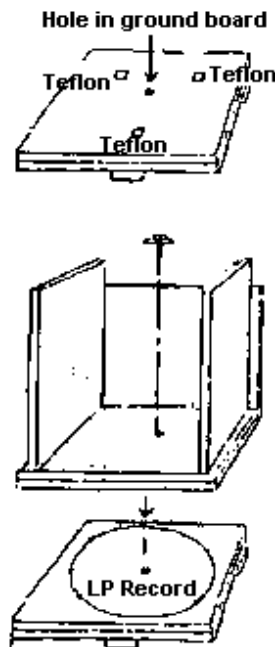

Teflon squares are underneath the record or *Plastic Laminate* (see note at left)

10) Now we are ready to balance the telescope and attach the **Cradle Boards** ([Part B](#)).

Cutting the Cradle Boards And Balancing The Tube

CUTTING THE CRADLE BOARDS

1) Use the two remaining pieces of Part B for the **Cradle Boards**.

2) The **Cradle Boards** need to be cut to hold the **Side Bearings** (circles). (Note: Cutting a V-shape is the simplest way to cut the **Cradle Boards** and is very satisfactory, but some people prefer to cut a semicircle for aesthetic reasons. (The V-shape can be easily cut with a handsaw.)

3) To cut the V-shape, find and mark the center of one of the boards ([Part B](#)). The angle of the "V" should be about 60 degrees. **Note:** *Lay your Side Bearings and Teflon onto the surface of your Cradle Boards to insure you cut away enough material so that your Side Bearings nestle nicely into the Cradle Boards.* Use a protractor to mark the "V" and cut it out with a hand saw (see below). Do both **Cradle Boards** the same way.

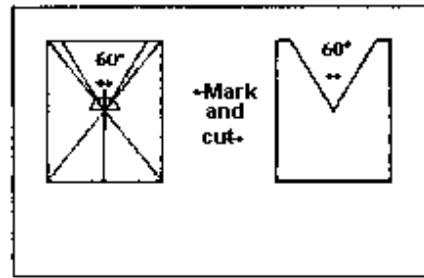

Cradle Boards (Part B)

BALANCING THE TUBE

- 1) To balance the tube we will need to install the primary mirror, the spider with the diagonal mirror in the telescope tube, an eyepiece, as well as any 1X finder or normal finder that you plan on using with your telescope. Remember: **HANDLE MIRRORS WITH CAUTION!!!**
- 2) Slide the telescope tube into the **Tube Box**. The fit of the tube should be snug in the Tube Box. If the fit is much too loose, a piece of masonite or thin plywood, or shim shingles (the kind you used for the spider) may be glued inside the **Tube Box** to tighten the fit as needed.
- 3) Slide the **Tube Box** along the tube to the spot where the weight of the telescope is *balanced* at the middle of the **Tube Box**. Use a broom stick handle to aid you in finding this balance point. Knowing this "balance point" will aid you in determining where (how high) to attach your **Cradle Boards**.

ATTACHING THE CRADLE BOARDS

- 1) The telescope's **Side Bearings** (the circles on the **Tube Box**) sit in the V-shaped notches in the **Cradle Boards**, allowing the telescope to be moved up and down easily. Position the **Cradle Boards** so that there will be at least 1" clearance between the lower end of the telescope tube (i. e. the tailgate end) and the **Bottom Board** of the **Rocker Box** when the telescope is sitting vertically in the Cradle Boards. The telescope must also be able to move forward into a nearly horizontal position without interference by the **Front Board**.
- 2) The **Cradle Boards**, when properly positioned, may be nailed or screwed to the **Side Boards** as shown, slightly forward of center (in

line with the bottom pivot bolt below). The **Cradle Boards** must be far enough back from the **Front Board** to allow the telescope to stand straight up in the rocker.

Note: Since the **Cradle Boards** may have to be moved around a few times to get the placement just right, it is a good idea to "tack" them in place with just a couple of nails while you are making adjustments. Glue and nail--or screw--them firmly in place later.

Another note: **Cradle Boards** are not found on any commercial "Dobs," and few homemade ones, anymore. Most just incorporate these "altitude bearing holders" into the Side Boards. The advantage of Cradle Boards (other than being simple to design and manufacture) is that they stiffen up the side boards a bit, as well as widen the "footprint" of our base ("Ground Board"); thereby adding stability and rigidity. This is a good thing.

[We will henceforth refer to the **Tube Box**-and-tube assembly (with mirrors installed) as the "**telescope**." The mount in which the telescope sits will be referred to as the "**rocker**".]

3) To enable the telescope to move smoothly in the up-and-down direction, we nail small pieces of Teflon at the points where the **Side Bearings** contact the **Cradle Boards**. Place the telescope in the rocker. Make a mark on the wood of each of the V-shaped notches at the two points where the **Side Bearings** make contact.

4) Nail a small piece of Teflon at each of the four marked contact spots (two on each side). Let the Teflon protrude a little over the inside edge of the **Cradle Boards** to keep the **Tube box** away from the **Cradle Boards**. Use finish nails and set the nails with a nail set. Place the telescope back in the rocker. The **Side Bearings** should glide smoothly on the Teflon.

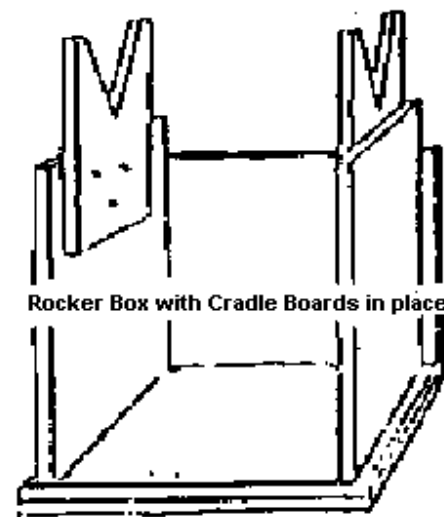

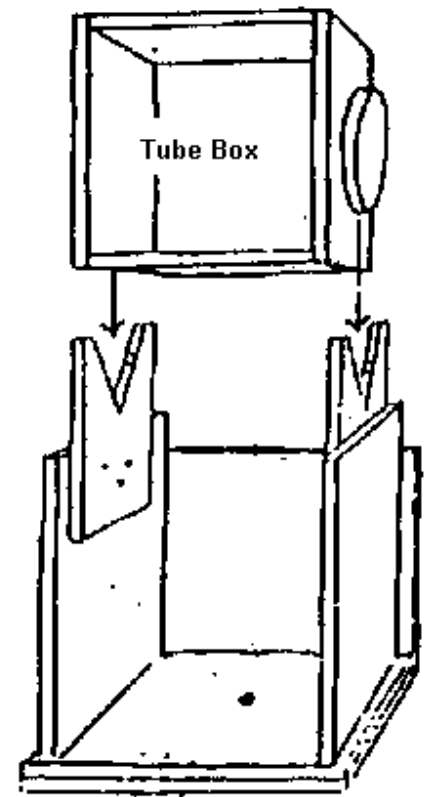

ALIGNING THE DIAGONAL

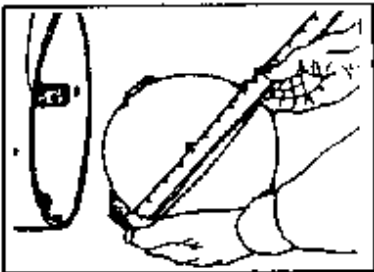

As mentioned earlier, a small sticker or decal should be placed at the exact center of your primary mirror. Visit your local stationary store--I like to use a "hole reinforcement" or a "gold star." This sticker is used to help in the alignment of both the objective and the diagonal. Don't worry: this does not harm your telescope in any way--this sticker is well inside the shadow your diagonal mirror casts.

-
- 1) Set up the telescope (i. e. place the telescope with the spider and objective installed, in the rocker).

- 2) Adjust the spider in the tube in such a way that you can see the entire objective mirror reflected in the diagonal mirror. You should be able to see the ENTIRE OBJECTIVE MIRROR, not just a part of it. Be sure your eye is centered over your eyepiece tube.
- 3) Place a piece of metal tubing (about 6" long—the same width as the piece in which your eyepiece is nestled) inside the cardboard eyepiece tube, so that it protrudes out several inches. Now think of the two ends of this metal tube as CIRCLES.
- 4) When you look down the metal tube, the CIRCLES (i. e. the two ends of the tube) SHOULD APPEAR CONCENTRIC, AND THE DECAL ON THE MIRROR SHOULD BE EXACTLY IN THE CENTER OF THESE CONCENTRIC CIRCLES. You will see the three legs (shingles) of the spider reflected in the objective, but for now, ignore them.

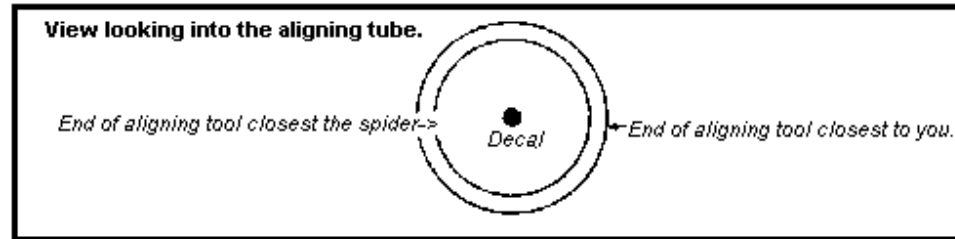

The way to get the alignment perfect is by fiddling with the position of the spider in the tube. When you have it just right, you can glue the spider in place. Apply a line of glue on either side of each shingle where it contacts the tube--100% black silicone glue works well here.

(Note: Before installing the spider you may wish to screw a small eye-hook dead-center into the 90 degree cut end of the wood block that supports the diagonal. After the spider is installed, another eye-hook may be screwed into the telescope tube, and a string may be tied between the two eye-hooks. This will protect the objective mirror if the spider is accidentally knocked out).

ALIGNING THE OBJECTIVE

Remember: Do this indoors or in the shade!

We have come now to the final step: aligning the objective mirror.

(We won't need the aligning tube anymore).

To align the objective mirror, we turn the tailgate bolts till the reflection of the eye moves under the decal.

NOTE: If the alignment must be done in the dark, you may have to shine a light on your mirror face in order to see the reflection of your eye in the objective.

Through the eyepiece hole, it should look something like this:

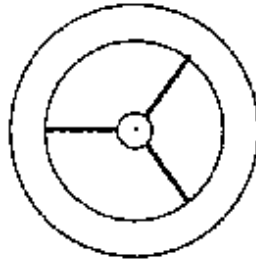

Keep the mirror pulled back against the tailgate during alignment.

Note: If you have a friend turn the bolts, you can watch which way the mirror moves--it is more difficult if you are doing it by yourself. Call the bolts "yours," "mine," and "ours": representing the furthest bolt from you; the nearest bolt; and the middle bolt (top) one, respectively. ;-)

Go use your scope! ...After you know everything works well, you can paint and finish to your desire!

A Few Finishing Tips:

Eighty-percent of a good finish is preparation. Fill any glaring holes or gaps in your plywood mount with putty or spackle (the latter only if you plan to paint it an opaque color). Take the extra time to sand your mount, especially "breaking the edges"--rounding them, if you will; so that no loose splinters come to harm anyone. If you plan to stain your mount, first experiment on a piece of scrap plywood--not all woods (birch and fir, come to mind), take stain well. Use a weatherproof paint; or varnish, or polyurethane as a final coat over stain. Be sure to seal any raw edges, including the cardboard tube, which is particularly sensitive to moisture.

Some folks use sticky-backed shelf paper to wrap their telescope tubes in. I use *Monocoat* or *Ultracoat*, found at your local hobby store: it is used to wrap model wooden airplane wings and fuselages. It is a little pricey; but it "shrink wraps" with the aid of an iron into a beautiful, glossy, weatherproof finish for your tube. Comes in lots of colors, too!

Sight down an edge of your Tube Box; that's how you aim the thing! (Of course, to make aiming a little more convenient and fun, you can add a 1-power aiming device like a Telrad or Rigel Systems QuikFinder, or even a finder scope.)

Care Instructions:

Do not store your scope outside. If you don't have a large closet or garage, put a lampshade on your scope and store it in your living room!

Remember: Door jambs destroy homemade focusers!

Cover your scope when not in use--dust and moisture--are the enemies! Plastic garbage bags, at both ends, work fine.

Despite your best efforts; your mirror will accumulate dust, and will require cleaning from time to time... Remember: this is a "first surface" mirror--a very fine deposit of aluminum is deposited on the surface--you do NOT want to introduce any "micro scratches" here! You can remove most of the dust with a rubber air blower (found at your local pharmacy store). Once or twice (at most) a year you should wash your primary. Here's how I do it:

First, you will need:

- 1) A suitable, clean tub.
- 2) A drop or two of mild (ivory) dishwashing soap.

3) A box of sterile cotton balls.

4) A gallon (or less) of distilled water.

1) Wash your sink, *Rubbermaid* tub, whatever, thoroughly.

2) Fill sink, whatever, with *room temperature* tap water (to avoid thermal shock between the layer of aluminum and the glass--this could help loosen the adhesion between the two surfaces--use only room temperature water throughout these steps); add one or two drops (ONLY) of dishwashing soap.

3) Submerge mirror in water. Swish around. Let soak.

4) Replace soapy water with fresh soapy water. Do not hold mirror under a running tap--some people do; I don't recommend it (localizing the "thermal shock" possibility, plus the danger of overdoing it with too much pressure).

5) With STERILE cotton balls wipe your mirror--from the center out--while mirror is still submersed. Be liberal in your use of the cotton balls (change frequently). *Roll* the cotton while swiping. Do not apply much pressure.

6) Replace soapy water with room temperature tap water to rinse away any soap.

7) With bottled, *distilled* water, rinse your mirror for a final time. (This removes any harmful salts that might be in your tap water). This is an important step--do not forget it!

8) Set mirror on edge to dry. Check on it in twenty minutes, or so. Any residual water droplets (usually just one or two) can be soaked up with any cotton balls you have left.

Back to: [Homepage](#), Table of Contents

To: [The San Francisco Sidewalk Astronomers](#)

E-mail: [Ray Cash](#)



David North looks through the author's Sun Scope



Key Materials:

- Partially aluminized parallel-plate glass (5% transmission). A "one way" mirror also works fine; the stuff, in other words, commonly used in casinos and department stores. Be sure to mount the aluminized surface **inside** (toward the primary).

The Dobsonian Sun Telescope

At left is an example of another contribution to amateur astronomy by John Dobson: an extremely safe Sun telescope.

One immediately notices the mirror tilted at 45-degrees at the front of the tube... This is actually a piece of one-way mirror, which serves two purposes: One, to deflect up to 95% of the incoming sunlight, thereby acting as a filter, and, two, to act like a normal diagonal mirror: to bounce the light gathered by the *unaluminized* primary out the side of the tube to be magnified by a suitable eyepiece--but not before this light passes through a welders' glass to filter out any harmful infrared or ultraviolet radiation.

Designed into this failsafe method to view the Sun, is this: If the front mirror is broken, or becomes accidentally dislodged, the viewer will be protected since no direct sunlight will reach the eyepiece; the eyepiece will, in fact, be pointed safely at the ground!

Construction Tips

Note that I have cut the telescope tube in half about 12" from the focuser--this is necessary since I glued (with 100% Silicone glue) the one-way mirror directly on the cardboard sonotube; it is necessary, that is, so I can mount, or de-mount, the focuser or welders' glass which is glued to the bottom of it. (Line--glue-- the inside of one half of the tube with "sleeve material,"--cardboard tube in which you have cut a section out, or other appropriately thin material). The focuser I use here is a **"2-inch to 1-1/4-inch adapter"**--a \$20 item available from telescope outfits like *Lumicon* or *Orion*. It is low and sturdy; and provides a flat bottom in which to glue the welders' glass. You will need to experiment with the grade of welders' glass you will need, by the way. My 6-incher requires a "grade seven," I believe. I would also recommend the "gold anodized" version of welders' glass over the traditional green glass--to yield a more natural, yellowish, transmission of light.

You must cut the front of the tube at *exactly* 45-degrees, if you glue the front mirror directly on the cardboard as I did. Tape enough 8-1/2" X 11"

- An **unaluminized** primary. Keep it small, 4.5" or 6" works just fine. Keep it "slow" F/8 or F/10.
- **Sonotube**. With a Sun Scope, we do not have to worry about "tube currents" and have our tube 2" larger in diameter than our primary--if you can fit your primary inside the tube, it will work fine.
- ***Sky and Telescope***, August '89 p.207ff. *Sidewalk Astronomer* Tom Mathews' article which inspired [me](#).

paper together end to end to go around your tube. Cut both ends at 45-degrees, making a trapezoidal shape. Bring the two ends together so that one edge of the paper is snug against the tube (some trimming will be required). Trace a line; cut to it.

With all that weight up front, you will have to make a tall rocker box, or use weight at the rear of your tube (I did both).

What will you see? Sunspots, faculae, granulation!



Frequently Asked Questions (FAQ's)

Q: How much is this going to cost?

You can research this as well as I can. The primary mirror will be your greatest expense, followed by eyepiece(s), accessories (like a 1-power finder), and your diagonal mirror. Some prices (as of 1/26/1999) are as follows (prices do not include shipping):

Mirrors (Primary + Diagonal--from [Coulter](#), as an example):

- 6" \$134.95+\$29.95
- 8" \$189.95+\$39.95
- 10" \$329.95+\$52.95

Eyepieces (from [Orion](#)):

- 26mm Plossl= \$49.95
- 10mm Plossl= \$49.95

One-Power Finder (from [Rigel Systems](#)):

- QuikFinder= \$39.95

Sonotube and other miscellaneous parts from these plans are incredibly inexpensive. A sheet of plywood will cost about \$30 (but you will use less than 1/2 a sheet if you make a six-incher... maybe you can scrounge scrap material from a local cabinetmaker?)

Remember: *The San Francisco Sidewalk Astronomers* have a long, proud tradition of helping folks make the least expensive/scrounged materials quality telescopes in the world!

There is nothing preventing you from spending more on your scope, however. A good commercial focuser can cost upwards of \$100; a diagonal mirror holder and spider can cost \$50, a commercial mirror cell can cost \$30...

Q: What eyepiece(s) should I get, and what power will I get from them?

I recommend Plossl eyepieces like the Orion ones above--good eyepieces, not too expensive. Power is determined by dividing eyepiece focal length into the telescopes' focal length--in millimeters. Let's take a six inch f/8 telescope, for example: 6×25.4 (the number of millimeters per inch)=152.4mm. Multiply this by your focal ratio (f/8, for example)=1,219.2 mm. Divide a 26mm eyepiece into this and you get 46.89 power. Divide the same 1,219.2 mm by an eyepiece with a 10mm focal length and you get 121.9 power, right? These are good focal length eyepieces to start out with; one low power, and one medium power... You may want to add to your collection later.

Q: What will I be able to see?

Jupiter and Saturn will probably be smaller than you like (at the 121x example given above), but you will be surprised at how much detail you can see: Many cloud bands on Jupiter, not to mention the four Galilean moons, as well as the great Red Spot (which is more pale yellow nowadays); cloud bands on Saturn as well as its glorious rings and (most likely) Cassini's division--the most notable gap in the rings. The Moon will be extremely detailed. Star clusters, nebulae, and galaxies (invisible to the naked eye) will vary considerably in their glory and appearance. Do not forget to allow your scope to come to ambient temperature ("cool-down")--this is extremely important! Otherwise, excess turbulence within your scope will produce nothing but "blobs" at the eyepiece! Allow at least an hour for cool-down time. Sometimes, the "seeing" (upper atmosphere turbulence) never settles down, and you will be frustrated with the views all night... nothing to do but try another night!

Q: Is a ten-inch scope that much better than a six or eight?

Size does matter, but as is often said: the best telescope is one that is used the most often... A smaller telescope is easier to handle, to transport, and will (generally) be used more often. I very much like six-inch f/8 or f/10 scopes for use in light polluted cities: images of the planets and the Moon are stunning through quality scopes of this aperture. Eight-inchers of faster focal ratios (say f/5.6) are also very manageable with ordinary vehicles, and often visually outperform similar aperture commercial Schmidt-Cassegrains costing upwards of \$2000! For ten-inchers, their aperture really comes into play at dark sites and with "deep-sky" objects. For this reason, especially if this is your first telescope, I recommend the smaller sizes unless you have ready access to dark skies, or know yourself to be a fanatic about this hobby already!

Q: How far away can I see with this size telescope?

The Sun is eight light minutes away; Jupiter a few hours; Saturn twice that distance; star clusters within our Milky Way are typically hundreds to thousands of light years away; galaxies are millions of light years distant, some billions... However, "How far away can I see?" is not really the question: The naked eye, for example, can see the Andromeda Galaxy which is 2.4 million light years away! Sure, any telescope will make the Andromeda clearer, and that is more to the point: The larger the diameter of the telescope, the more **resolving power** one has available to your eye/brain. Just as expensive computer monitors have more lines of **resolution**, and therefore display a more detailed image, a larger telescope

mirror will collect more light and is therefore capable of higher magnification and higher resolution; enabling us to detect more detail in celestial objects.

Q: Will I be able to see color... anything like the beautiful space photographs I have seen?

No. We have all been spoiled by the Hubble Space Telescope, NASA, *Star Trek* and other beautiful space images--real or imagined. However, there is no substitute for seeing the Universe as it really is through a telescope that you have made! I strongly suggest you attend a public "star party" in your locale and look through as many telescopes as you can. Go to <http://www.skypub.com/> for an extensive listing of astronomy clubs--to find one in your area.

Q: Can I take photographs through this telescope?

No. Dobsonians can be made to track with computers or equatorial platforms, but at quite an expense... Even so, these set-ups are generally for visual use, not photographic. For photographing the sky through a telescope, I suggest a different kind of telescope, with a different kind of mount. Be prepared to spend at least \$2000 on the telescope and another \$2000 on photographic accessories. In short, you are on the wrong Webpage!

Q: How long will it take me to make this telescope?

Oh, about two weekends, I would guess. I think you will find most of your time spent at the beginning and end of your project: the gathering of the materials; and the final sanding, painting and finishing--everything else goes pretty fast--and is quite satisfying.

Q: Can I use a PVC (plastic) tube instead of a Sonotube (cardboard concrete forming tube)?

It *has* been done; but it is not recommended, for several reasons: PVC warps with heat (like in the back seat of a car on a hot day); PVC also warps with weight, adding to collimation problems. PVC is also quite heavy.

Q: Even the six-inch scope in your plans is a bit ambitious for me and my young child--is there someone that makes a kit in a smaller size?

I now have plans for a 4.5" on the site!

Q: Where can I get a printed copy of these plans?

If you can't print--for whatever reason--from these pages, I suggest you contact the [Los Angeles Sidewalk Astronomers](#); last I heard, they are still sending out hard copies for \$2.00 from this address:

The Sidewalk Astronomers
1946 Vedanta Place
Hollywood, CA. 90068

If you are requesting these plans be mailed to another country, the price may be higher.

I do not send any plans through the mail, nor do I have any influence over those that do.

[HOME](#)